



SOLUTIONS FOR THE PAPER  
MANUFACTURING & TISSUE  
CONVERTING INDUSTRY

# Performance across the paper process

Expertise  
Passion  
Automation



# Driving performance in tissue & paper manufacturing

At SMC, we understand the unique challenges of the industry: tight margins, high energy demands and the constant need for reliable, efficient production. That's why we deliver solutions designed to meet your goals: **improving Overall Equipment Effectiveness (OEE), reducing operational costs and supporting sustainability initiatives.** Through digitalisation and Smart Flexibility, our solutions seamlessly integrate into your existing processes, providing real-time insights and adaptive control. The result? Higher productivity, enhanced reliability and a future-ready approach that will keep you competitive in a rapidly evolving market. Partner with SMC and **transform your operations into a smarter, more sustainable manufacturing environment.**

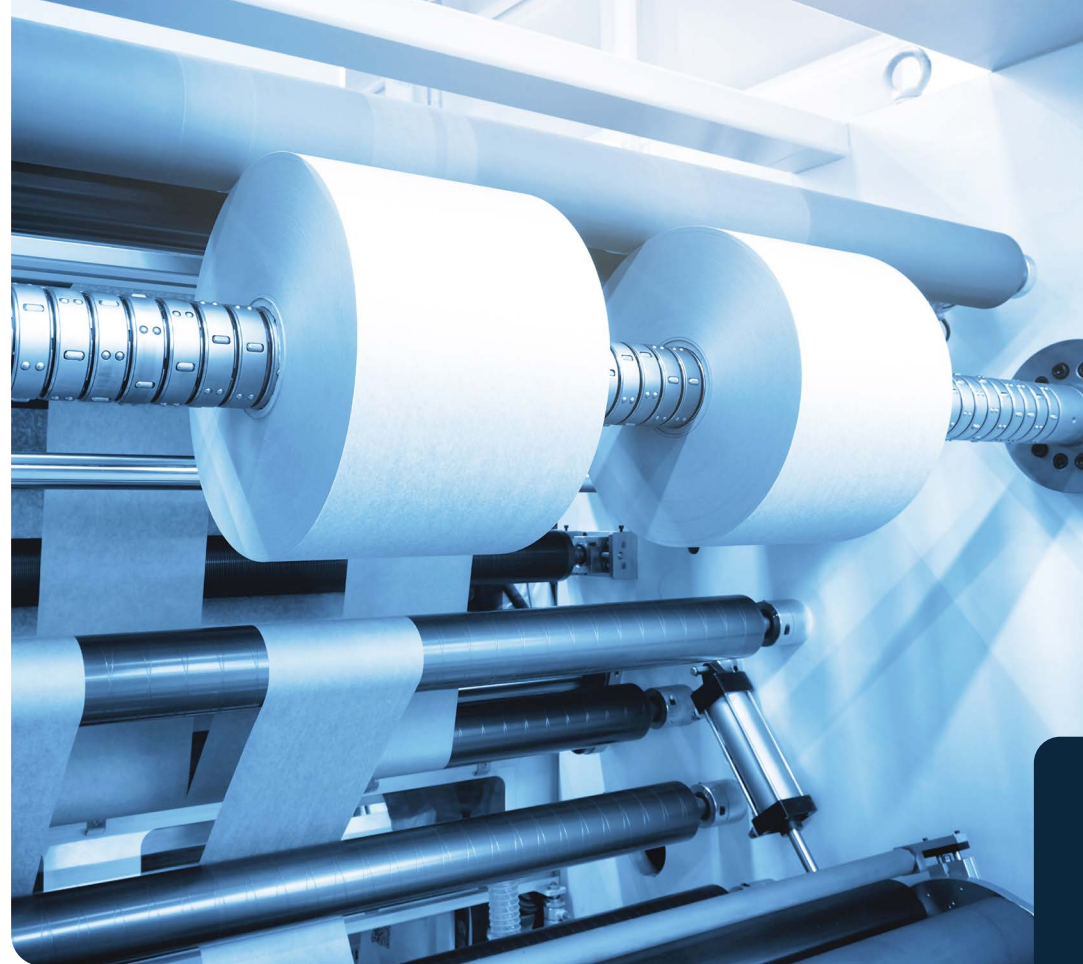

PAOLO GAMARINO  
Industry Manager

**Our strength in the tissue and paper sector lies in combining deep process expertise with true global reach. We support customers locally while leveraging worldwide engineering, service and supply chain capabilities, ensuring consistent performance, rapid response and optimised operations across the globe**

# Production line

The production line is the heart of tissue manufacturing, where pulp is transformed into high-quality tissue paper through a series of specialised stages.

Each stage plays a vital role in **delivering consistent quality, efficiency and performance**, forming the foundation for all subsequent converting processes. In this application, and throughout the entire process, we support our customers with **tailored solutions** designed around their specific machine configuration.

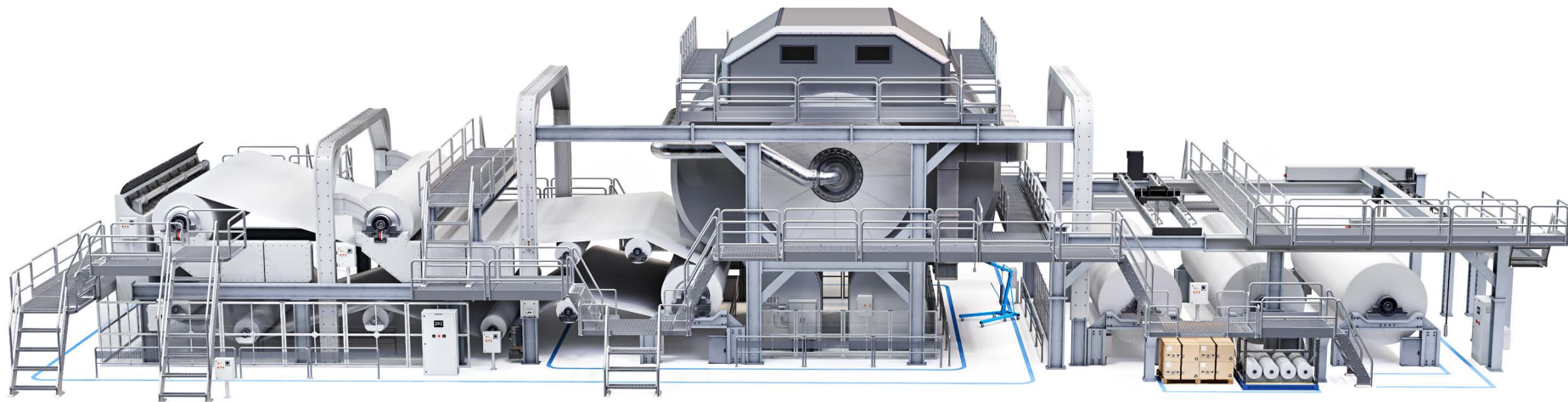

1

## Wet area

Pulp fibres are diluted, formed into a continuous sheet, and pressed to remove excess water. This stage is critical for achieving uniformity and strength in the tissue base.

2

## Dry area

After pressing, the sheet enters the drying section, typically involving large Yankee cylinders and hot air systems. In this step, having adequate tension control is essential because it ensures optimal quality of the product while preserving softness and bulk.

3

## Winder/Pope reel

Finally, the dried tissue is wound into large parent rolls (jumbo rolls) with precise tension control, ready for downstream converting operations.

# Wet area

In the wet end of tissue production, automation faces unique challenges due to the **highly variable and demanding** nature of the process. This section of the line involves handling pulp slurry with fluctuating moisture content, fibre consistency and temperature, all of which require precise control to maintain sheet formation quality. Equipment must **operate reliably in a humid, corrosive environment**, where traditional sensors and actuators often struggle with contamination and wear.

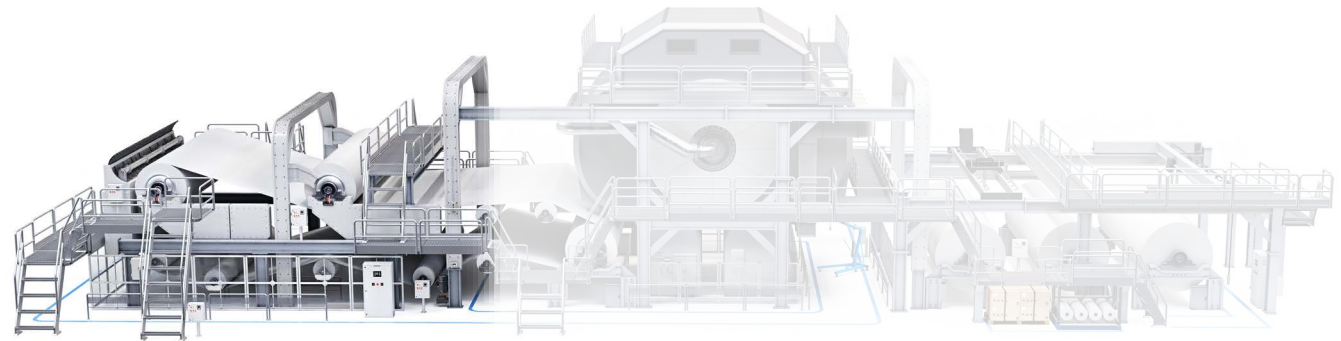

**AFF□DS Series +**

## Main line filter, stainless steel type

Ensure adequate air purity with an environmentally-resistant solution.



**JSX/JSXD/JSXZ/JSXU Series +**

## 2-port solenoid valve

Open and close the water passage process valve to manage the blower.



**IP8100 Series +**

## Electro-pneumatic positioner, rotary type

Guarantee accuracy and synchrony in handling operations.



**SY New Series +**

## 5-port solenoid valve

Assemble your customised manifold featuring next-generation communication systems.

**+ Try our valve configurator**

# Dry area

In the dry end of tissue production, automation needs to address critical challenges related to **tension monitoring and control**. As the sheet transitions from the wet section to high-speed drying and winding processes, maintaining precise web tension is essential to prevent tears, wrinkles and uneven roll formation. Variations in speed, diameter and material properties demand advanced control systems capable of **real-time adjustments**.

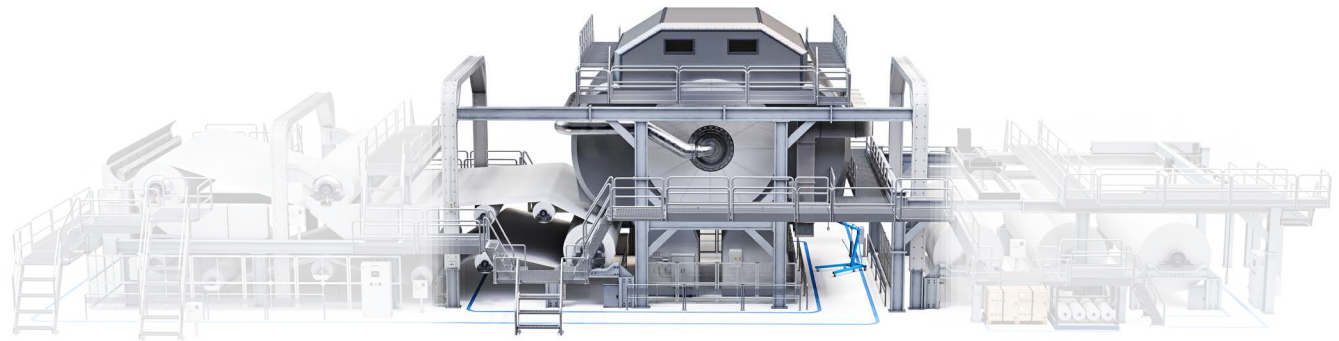

## FACTS OVER WORDS

### Digitalising a production line

Our customer needed a solution to manage acyclic functions on the production line, such as valve on/off counting and counter value reset.

A key requirement was to ensure **high machine efficiency, supported by transparent and readily available data** to enable close monitoring, control and continuous process optimisation.

By implementing **the EX600 Fieldbus Unit with OPC UA communication**, the customer deployed a digital solution without the need for PLC programming. This approach significantly reduced wiring complexity and delivered measurable cost savings.



### ISE20 Series +

#### High-precision digital pressure switch

Achieve precise pressure monitoring in loading and unloading with IO-Link.



### VQC Series +

#### Pilot operated 4/5-port solenoid valves

Facilitate wiring and PLC commands for management of tension control.



### EX600-SPN31 Series +

#### Fieldbus unit

Acquire machine cycle data and transmit it through OPC UA directly to the computer.



# Winder and pope

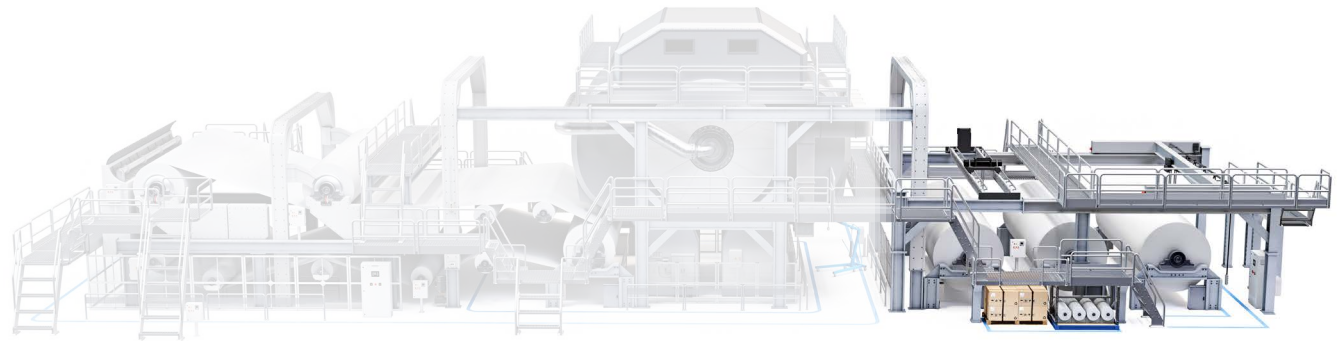

At the winder and pope reel stage, automation must **ensure flawless roll formation while prioritising safety and reliability**. This process involves managing high forces during reel changes and **maintaining precise force control** to avoid sheet damage or core deformation. Flushing systems play a critical role in keeping pneumatic components clean and free from dust and fibre buildup, ensuring consistent performance in a challenging environment.



**VPX400 Series +**

## Safe exhaust valve, modular connection type

Allow for division into separate, independent zones and complete discharge of the pneumatic line.



**C95 Series +**

## ISO/VDMA cylinder, large bore size

Make handling big-diameter rollers easier.



**AMS20/30/40/60 Series +**

## Air Management System

Monitor and automatically control the conditions of the air supply for optimised compressed air consumption.



**ITV Series +**

## Electro-pneumatic regulator/ electronic vacuum regulator

Contribute to sheet tension arrangement by precisely controlling air pressure.

# Converting line

In the tissue industry, the converting line is where raw jumbo rolls are transformed into finished consumer products with efficiency and quality. This process involves several critical applications that form the backbone of tissue converting, delivering products that meet high standards of **performance, aesthetics and consumer satisfaction.**

A key step that enhances product softness, thickness and visual appeal by applying decorative or functional patterns to the tissue.

The web is folded into the desired format, requiring high-speed, repeatable motion control to maintain dimensional accuracy and consistent stack formation. Reliable actuation and perfect timing are critical to protect product quality and optimise output.

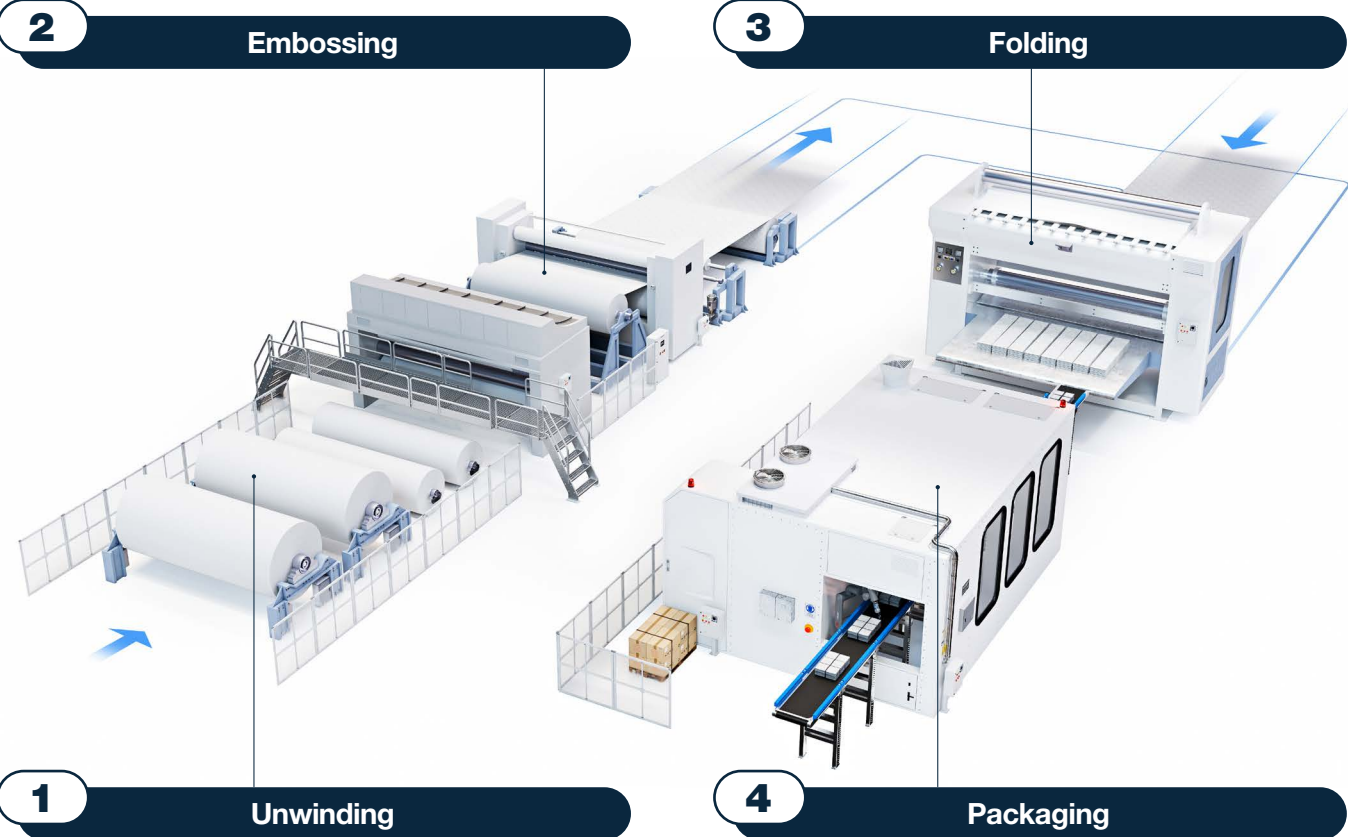

The starting point of the line, where large parent rolls are carefully unwound to maintain sheet integrity and ensure smooth downstream operations.

Finally, the finished stacks are wrapped, sealed and prepared for shipment. Efficient automation ensures accurate counting, secure sealing and smooth handling, supporting traceability and reducing downtime.

# Unwinding

A smooth material feed without costly disruptions is the key to success in the unwinding process. Large parent rolls must be handled with precision to maintain consistent web tension as the sheet enters the converting line. Advanced control systems are essential to compensate for variations in roll diameter and material properties, avoiding tears or wrinkles that may compromise product quality.

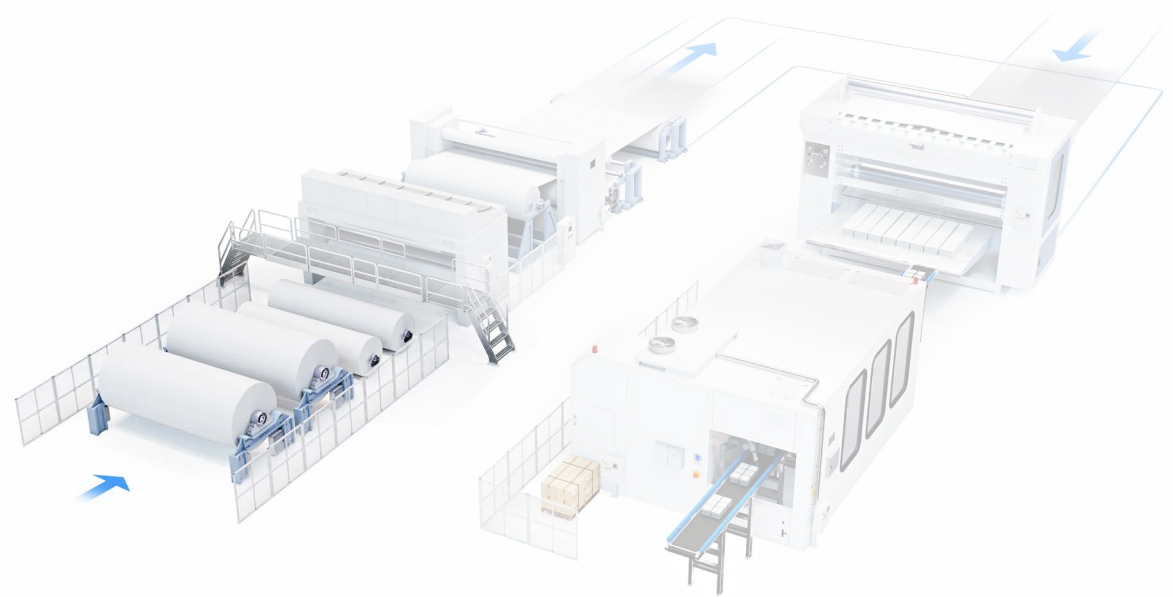

AXTS Series +

## Pulse blow valve

Blow efficiently with a pulse-controlled, long-life alternative.



XT34-303 Series +

## Pilot check valve with state detection

Monitor the cylinder lock directly with a safety function.



VBAF Series +

## Pressure booster

Increase pressure in certain areas of the line depending on actual needs.



EX600-SPN31 Series +

## Fieldbus unit

Acquire machine cycle data and transmit it through OPC UA directly to the computer.



### Facts over words Tangible cost savings in roll cleaning

During the finished product accumulation phase, the customer needed to **keep roll channels clean** for toilet paper and industrial rolls. The existing solution used continuous blowers, resulting in high air consumption.

By introducing SMC impulse valves, AXTS series, **continuous blowing was eliminated** in favour of targeted, high-pressure air bursts. This delivered significant **energy savings while improving cleaning performance**.

# Embossing

Embossing enhances tissue softness, bulk and visual appeal by pressing patterns into the sheet. Automation plays a key role in this process, facing challenges such as maintaining precise pressure, synchronising rolls for perfect pattern alignment, controlling web tension and ensuring **repeatable and consistent quality through active monitoring**.

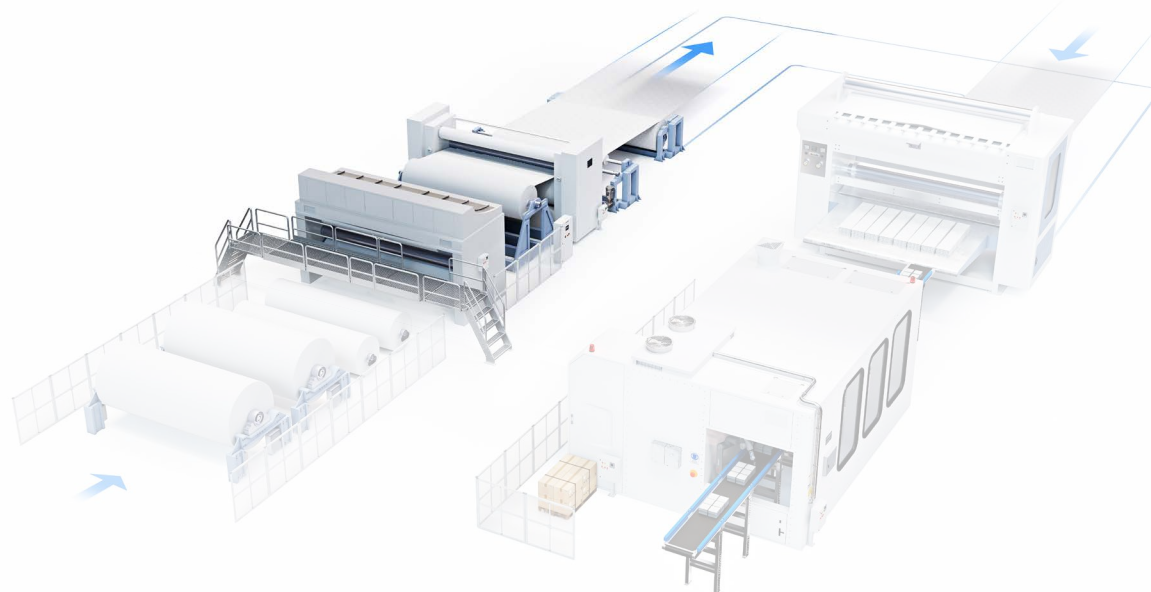

## Facts over words A reliable safety stop for embossing machines

A customer operating in the tissue converting segment needed **reliable mechanical blocking in the event of an emergency or controlled machine stop**. Given the high forces involved, the application places stringent demands on both performance and safety.

SMC supplied the ISO-compliant cylinder, C96 series, specifically designed to meet these requirements, ensuring secure and repeatable blocking under all operating conditions. One of the solution's key differentiators is its **certified compliance with Machinery Directive 2006/42/EC**, providing the customer with full regulatory assurance.



C96 Series +

### ISO cylinder

Standardise your actuators for flexibility.



PF3A□H Series +

### Digital flow switch for large flow, modular type

Measure air consumption in individual machine zones.



HRS Series +

### Circulating fluid temperature controller, standard type

Protect the process with stable and precise temperature control.

# Folding

Industrial paper folding lines run at high cycle speeds, where **precision in position, repeatability and force control** has a direct impact on fold quality and the stability of the stacked output. The process must handle lightweight, electrostatically charged sheets and guide them through folding, transfer and stacking without causing wrinkles, marks or misalignment, all while staying perfectly synchronised with other equipment. Because these systems operate continuously, they also require a **robust communication setup, compact and efficient equipment and dependable technology** to keep performance consistent.

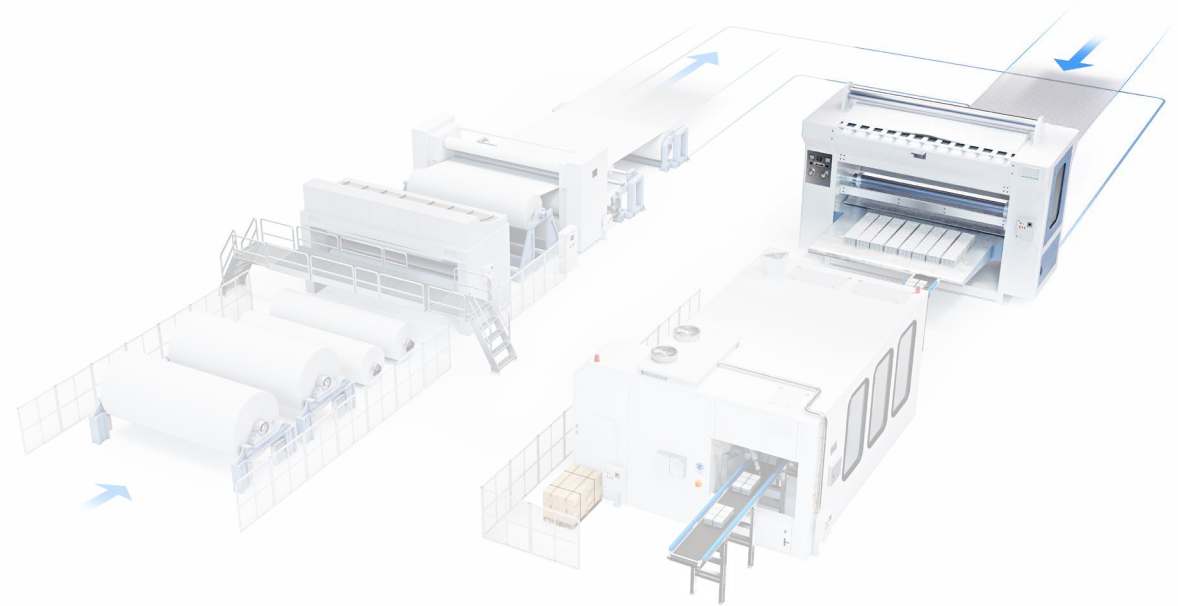

C55-Z Series +

## ISO compact cylinder

Save space and reduce cycle time with a compact, lightweight solution.



JSX/JSXD/JSXZ/JSXU Series +

## 2-port solenoid valve

Withstand demanding conditions without compromising performance of blowing operations.



EX260-SIL Series +

## Compact fieldbus system for output

Benefit from the advantages of IO-Link with a versatile serial node for valve manifolds.



IZN10E Series +

## Nozzle type ionizer

Combine static control with air blowing for an effective cleaning.

# Packaging

Packaging in the tissue industry demands an exceptional balance of **flexibility, speed and reliable quality**. Frequent format changes, high production rates and delicate products leave little margin for error. SMC's solutions are designed to support manufacturers in meeting these challenges, enabling efficient, reliable and high-quality packaging processes across the entire line.

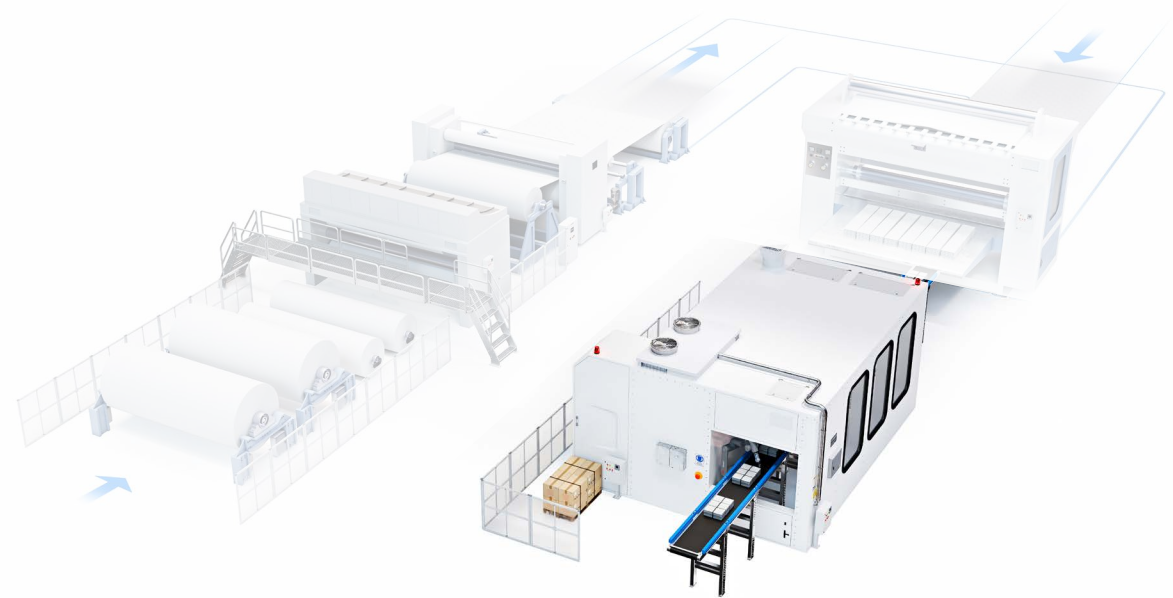

MGP Series +

## Compact guide cylinder

Transfer packaged products reliably.



IZS51 Series +

## Bar type ionizer

Avoid faults in final packaging derived from adhesion of particles.



EXW1 Series +

## Compact wireless system

Expand flexibility of communications while maintaining a lightweight design.

# Our support network

## SMC's worldwide commitment

One of the things we do best at SMC is **being close to our customers**. Local support, on a global scale.

With **support** in over **500 locations** across **80 countries** and regions **worldwide**, our sales force of **7000 experts** maintains **close communication with customers**.



# SMC Business Continuity Plan

## Sustainable growth also means ensuring uninterrupted operations

We are committed to ensuring that SMC is prepared for any emergency and that our business activities will not stop in the event of such circumstances. SMC aims to fulfil our product supply responsibilities and maintain our customers' trust by contributing to both sustainable growth and the expansion of technological innovations.

SMC, as a comprehensive manufacturer of automatic control equipment that supports automation, is able to promptly provide products that meet our customers' needs anywhere in the world.

## Production BCP

### Ensure customer order fulfilment

Reliable delivery for you thanks to our 9 global logistic centres and 38 production sites worldwide. Moreover, flexibility to rapidly respond to any sudden change in the manufacturing environment.

## Finance BCP

### Safe & Solid financial base

In the event of an emergency, SMC can provide a safe and solid financial base (with cash, deposits, and equity capital) that will sufficiently cover the working capital and funds needed to rebuild buildings and the equipment required for business continuity. This is done to provide peace of mind to our customers and workers alike.

## Information security BCP

### Vital data kept safe

Strengthen information security for protection against computer viruses and cyberattacks, plus the installation of data centres to establish a disaster recovery system. Your information is safe with us.

## Engineering BCP

### Consistent technical support

2,000 engineers at our 5 technical centres around the globe.

## Sales BCP

### Consistent sales support

7,000 sales engineers worldwide ready to recommend the best solution for you. Over 80 global locations to make sure that wherever you are, we are there too.



[Discover more](#)



## SMC Corporation

1-5-5, Kyobashi,  
Chuo-ku, Tokyo  
104-0031, Japan  
Telephone: 03-6628-3000  
<https://www.smcworld.com>

<b>Austria</b>	+43 (0)2262622800	<a href="http://www.smc.at">www.smc.at</a>	<a href="mailto:office.at@smc.com">office.at@smc.com</a>						
<b>Belgium</b>	+32 (0)33551464	<a href="http://www.smc.be">www.smc.be</a>	<a href="mailto:info@smc.be">info@smc.be</a>						
<b>Bulgaria</b>	+359 (0)2807670	<a href="http://www.smc.bg">www.smc.bg</a>	<a href="mailto:sales.bg@smc.com">sales.bg@smc.com</a>						
<b>Croatia</b>	+385 (0)13707288	<a href="http://www.smc.hr">www.smc.hr</a>	<a href="mailto:sales.hr@smc.com">sales.hr@smc.com</a>						
<b>Czech Republic</b>	+420 541424611	<a href="http://www.smc.cz">www.smc.cz</a>	<a href="mailto:office.at@smc.com">office.at@smc.com</a>						
<b>Denmark</b>	+45 70252900	<a href="http://www.smc.dk">www.smc.dk</a>	<a href="mailto:smc.dk@smc.com">smc.dk@smc.com</a>						
<b>Estonia</b>	+372 651 0370	<a href="http://www.smcee.ee">www.smcee.ee</a>	<a href="mailto:info.ee@smc.com">info.ee@smc.com</a>						
<b>Finland</b>	+358 207513513	<a href="http://www.smc.fi">www.smc.fi</a>	<a href="mailto:smc.fi@smc.com">smc.fi@smc.com</a>						
<b>France</b>	+33 (0)164761000	<a href="http://www.smc-france.fr">www.smc-france.fr</a>	<a href="mailto:supportclient.fr@smc.com">supportclient.fr@smc.com</a>						
<b>Germany</b>	+49 (0)61034020	<a href="http://www.smc.de">www.smc.de</a>	<a href="mailto:info.de@smc.com">info.de@smc.com</a>						
<b>Greece</b>	+30 210 2717265	<a href="http://www.smchellas.gr">www.smchellas.gr</a>	<a href="mailto:sales@smchellas.gr">sales@smchellas.gr</a>						
<b>Hungary</b>	+36 23513000	<a href="http://www.smc.hu">www.smc.hu</a>	<a href="mailto:office.hu@smc.com">office.hu@smc.com</a>						
<b>Ireland</b>	+353 (0)14039000	<a href="http://www.smcautomation.ie">www.smcautomation.ie</a>	<a href="mailto:technical.ie@smc.com">technical.ie@smc.com</a>						
<b>Italy</b>	+39 03990691	<a href="http://www.smcitalia.it">www.smcitalia.it</a>	<a href="mailto:mailbox.it@smc.com">mailbox.it@smc.com</a>						
<b>Latvia</b>	+371 67817700	<a href="http://www.smc.lv">www.smc.lv</a>	<a href="mailto:info.lv@smc.com">info.lv@smc.com</a>						
<b>Lithuania</b>	+370 5 2308118	<a href="http://www.smclt.lt">www.smclt.lt</a>	<a href="mailto:info.lt@smc.com">info.lt@smc.com</a>						
<b>Netherlands</b>	+31 (0)205318888	<a href="http://www.smc.nl">www.smc.nl</a>	<a href="mailto:info@smc.nl">info@smc.nl</a>						
<b>Norway</b>	+47 67129020	<a href="http://www.smc-norge.no">www.smc-norge.no</a>	<a href="mailto:post.no@smc.com">post.no@smc.com</a>						
<b>Poland</b>	+48 22 344 40 00	<a href="http://www.smc.pl">www.smc.pl</a>	<a href="mailto:office.pl@smc.com">office.pl@smc.com</a>						
<b>Portugal</b>	+351 214724500	<a href="http://www.smc.eu">www.smc.eu</a>	<a href="mailto:apoiocliente.pt@smc.com">apoiocliente.pt@smc.com</a>						
<b>Romania</b>	+40 213205111	<a href="http://www.smcromania.ro">www.smcromania.ro</a>	<a href="mailto:office.ro@smc.com">office.ro@smc.com</a>						
<b>Russia</b>	+7 (812)3036600	<a href="http://www.smc.eu">www.smc.eu</a>	<a href="mailto:sales@smcru.com">sales@smcru.com</a>						
<b>Slovakia</b>	+421 (0)413213212	<a href="http://www.smc.sk">www.smc.sk</a>	<a href="mailto:sales.sk@smc.com">sales.sk@smc.com</a>						
<b>Slovenia</b>	+386 (0)73885412	<a href="http://www.smc.si">www.smc.si</a>	<a href="mailto:office.si@smc.com">office.si@smc.com</a>						
<b>Spain</b>	+34 945184100	<a href="http://www.smc.eu">www.smc.eu</a>	<a href="mailto:post.es@smc.com">post.es@smc.com</a>						
<b>Sweden</b>	+46 (0)86031240	<a href="http://www.smc.nu">www.smc.nu</a>	<a href="mailto:order.se@smc.com">order.se@smc.com</a>						
<b>Switzerland</b>	+41 (0)523963131	<a href="http://www.smc.ch">www.smc.ch</a>	<a href="mailto:helpcenter.ch@smc.com">helpcenter.ch@smc.com</a>						
<b>Turkey</b>	+90 212 489 0 440	<a href="http://www.smcturkey.com.tr">www.smcturkey.com.tr</a>	<a href="mailto:satis.tr@smc.com">satis.tr@smc.com</a>						
<b>UK</b>	+44 (0)845 121 5122	<a href="http://www.smc.uk">www.smc.uk</a>	<a href="mailto:sales.gb@smc.com">sales.gb@smc.com</a>						
<b>South Africa</b>	+27 10 900 1233	<a href="http://www.smcza.co.za">www.smcza.co.za</a>	<a href="mailto:Sales.za@smc.com">Sales.za@smc.com</a>						

## www.smc.eu

Release ES  
TISS-01A-EN

SPECIFICATIONS ARE SUBJECT TO CHANGE WITHOUT PRIOR NOTICE AND ANY OBLIGATION ON THE PART OF THE MANUFACTURER