

For 4 Axes Simple Controller



End to end

2-point operation is possible without programming!

- **Reduced setting labour**
Only the speed and force need to be set
- **Reduced wiring labour**
Only 2 inputs/outputs*1
*1 Per axis
- **Space saving**



Footprint Reduced by up to approx. **79 %**
Single-axis controller (LECP6) x 4 controllers

Footprint Reduced by up to **73 %**
4-axis controller (JXC73/83/93)

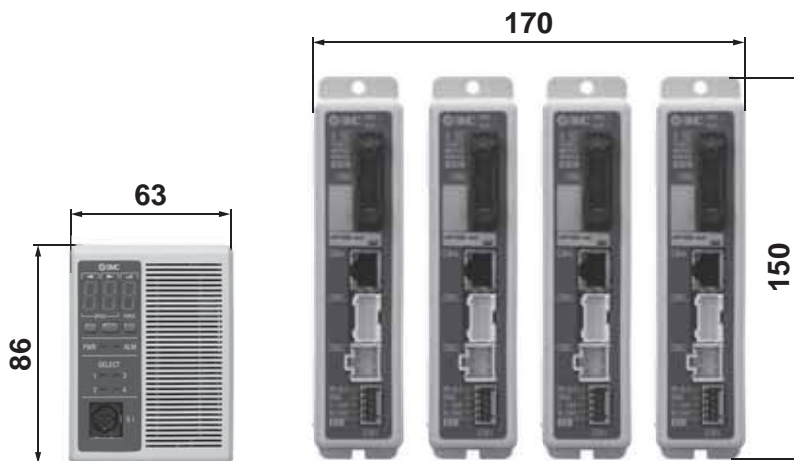

- **Applicable actuator**
LEY Series
Size 16, 25



JXC□4-X1

System Construction

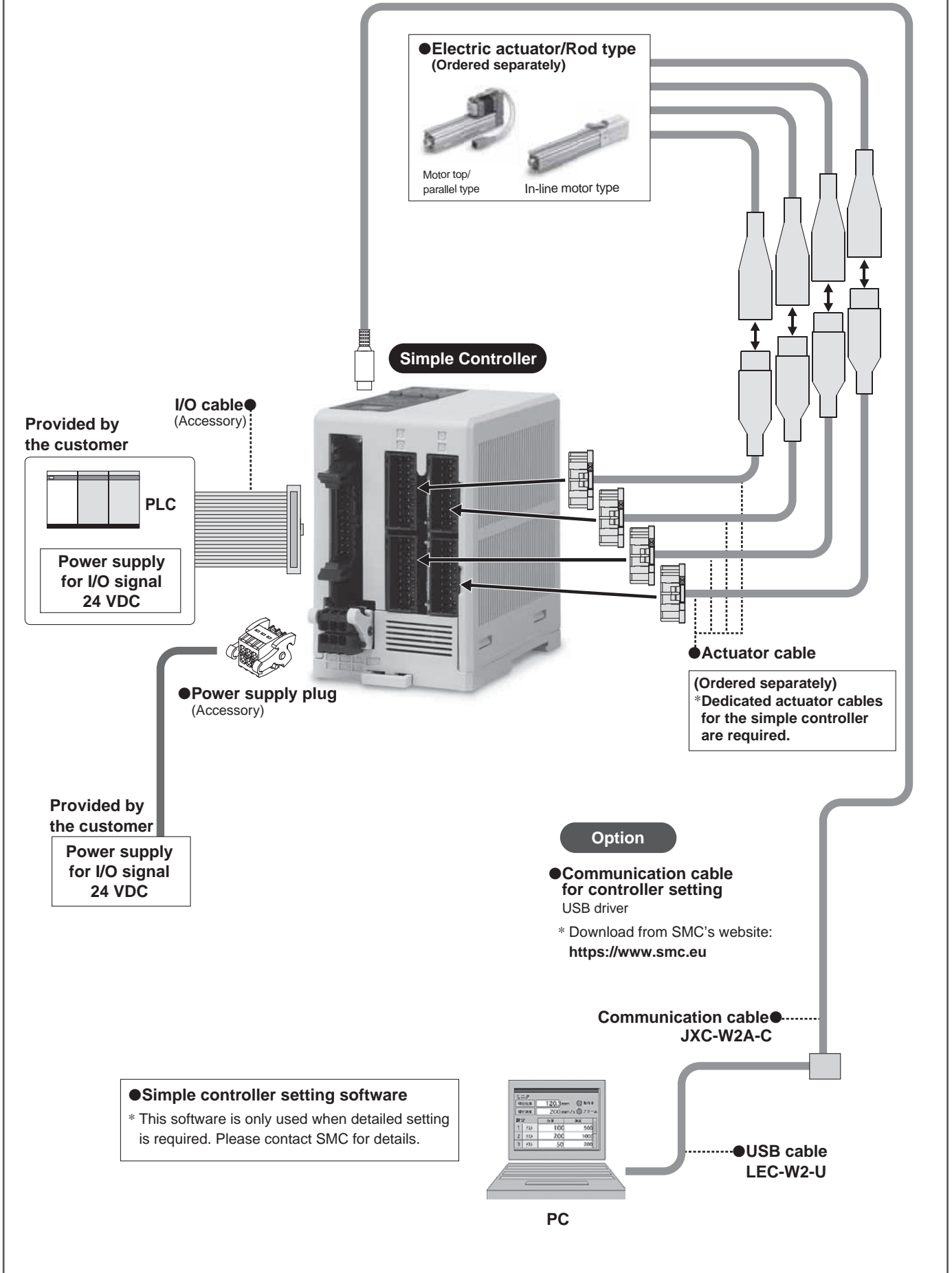

Specifications

Model	JXC□4-X1
Number of axes	4 axes
Compatible motor	Step motor (Servo/24 VDC) □42/□28/□20
Power supply	Power voltage: 24 VDC ±10 %
Power consumption	Power consumption depends on the actuator size connected. Refer to the actuator specifications for further details.
Operating temperature range	0 to 55°C (No freezing)
Operating humidity range	90 % or less (No condensation)
Insulation resistance	Between all external terminals and the case 50 MΩ (500 VDC)
Weight	300 g (DIN rail mounting), 390 g (Screw mounting)
Applicable actuator	LEY Series (Size 16, 25 * Excluding the LEYG)

Dimensions

* Mountable on DIN rail (35 mm)

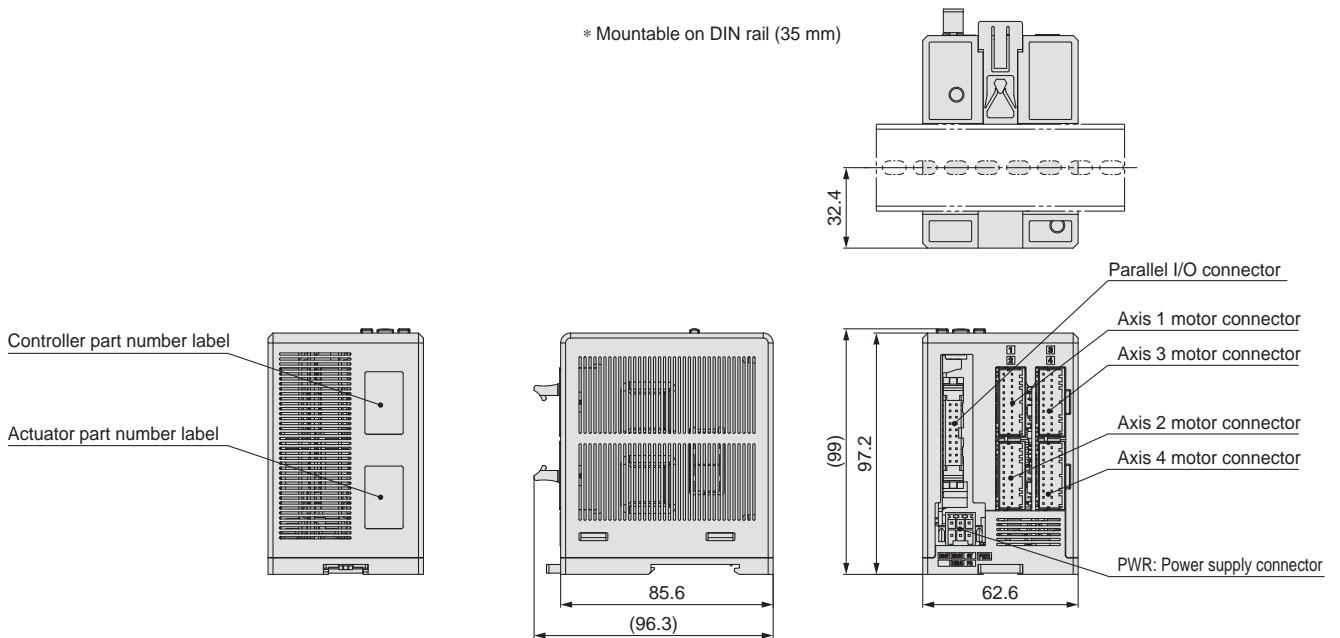

Screw mounting

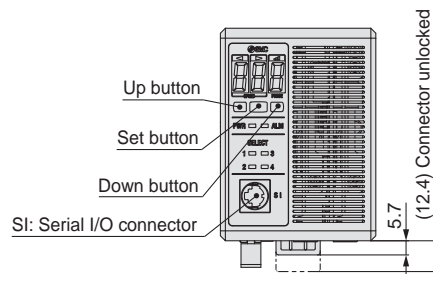
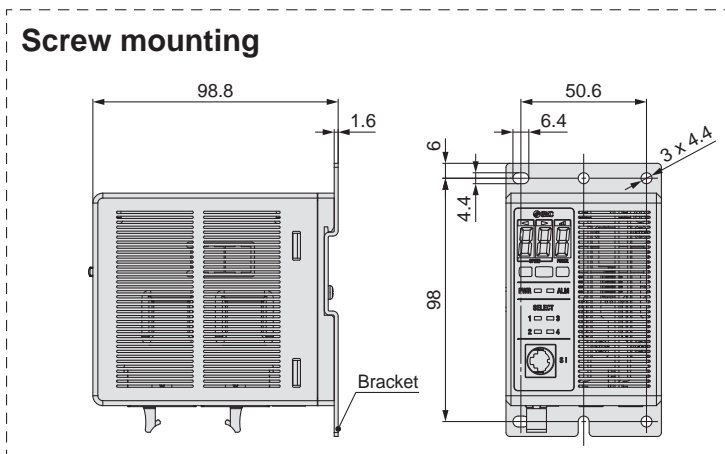

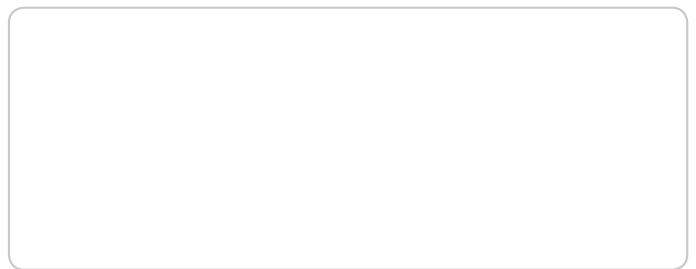

SMC Corporation (Europe)

Austria	+43 (0)2262622800	www.smc.at	office@smc.at
Belgium	+32 (0)33551464	www.smc.be	info@smc.be
Bulgaria	+359 (0)2807670	www.smc.bg	office@smc.bg
Croatia	+385 (0)13707288	www.smc.hr	office@smc.hr
Czech Republic	+420 541424611	www.smc.cz	office@smc.cz
Denmark	+45 70252900	www.smc.dk.com	smc@smc.dk.com
Estonia	+372 6510370	www.smc.pneumatics.ee	info@smc.ee
Finland	+358 207513513	www.smc.fi	smc.fi@smc.fi
France	+33 (0)164761000	www.smc-france.fr	info@smc-france.fr
Germany	+49 (0)61034020	www.smc.de	info@smc.de
Greece	+30 210 2717265	www.smchellas.gr	sales@smchellas.gr
Hungary	+36 23513000	www.smc.hu	office@smc.hu
Ireland	+353 (0)14039000	www.smc.automation.ie	sales@smc.automation.ie
Italy	+39 03990691	www.smc.italia.it	mailbox@smc.italia.it
Latvia	+371 67817700	www.smc.lv	info@smc.lv

Lithuania	+370 5 2308118	www.smclt.lt	info@smclt.lt
Netherlands	+31 (0)205318888	www.smc.nl	info@smc.nl
Norway	+47 67129020	www.smc-norge.no	post@smc-norge.no
Poland	+48 222119600	www.smc.pl	office@smc.pl
Portugal	+351 214724500	www.smc.eu	apoioclientept@smc.smces.es
Romania	+40 213205111	www.smcromania.ro	smcromania@smcromania.ro
Russia	+7 8123036600	www.smc.eu	sales@smcru.com
Slovakia	+421 (0)413213212	www.smc.sk	office@smc.sk
Slovenia	+386 (0)73885412	www.smc.si	office@smc.si
Spain	+34 945184100	www.smc.eu	post@smc.smces.es
Sweden	+46 (0)86031200	www.smc.nu	smc@smc.nu
Switzerland	+41 (0)523963131	www.smc.ch	info@smc.ch
Turkey	+90 212 489 0 440	www.smc.pnomatik.com.tr	info@smc.pnomatik.com.tr
UK	+44 (0)845 121 5122	www.smc.uk	sales@smc.uk

SMC Corporation Akihabara UDX 15F, 4-14-1, Sotokanda, Chiyoda-ku, Tokyo 101-0021, JAPAN Phone: 03-5207-8249, Fax: 03-5298-5362