



ELECTRIC ACTUATORS & KEY TRENDS

# Motion in your power



Expertise  
Passion  
Automation



## Where smart motion begins

Each factory should run effortlessly. Machinery working efficiently with parts moving, tools shifting, lines adapting and with people making it all happen. SMC believes that behind each movement lies an opportunity: to make things simpler, safer, smoother... to put performance in motion and let automation support your ideas instead of machinery holding them back.

**At SMC, we believe motion should feel effortless.**

**It should assist with your creativity, not limit it.**

**It should give you reliability, not complexity.**

That's why our electric actuator solutions are designed to remove obstacles. Compact controllers that fit neatly into your cabinet. Teaching tools that make setup feel intuitive. Safe, reliable systems that protect your people and your process. Modular assemblies that grow at the same pace as your production needs.

Because when motion becomes easy, truly easy, everything else moves forward with it.

This is precision without complication. This is technology that adapts, guides and evolves.

**This is performance  
in motion.**

---

# Index

## 4 Movement control

## 5 Motor type

## 6 Controller type

## 7 Key trends

7 Wireless integration with electric actuators

8 e-Actuator

10 Manifold controller

11 Electric actuators with improved ingress protection

12 Controllers with STO functionality

13 LEA multi-axis system mounting kit

14 Electric actuators with absolute encoder

15 Teaching box

16 Collaborative robots

## 17 Everything you need in one place

## 18 Electric actuators technical data

18 Slider type



20 Slide table



21 Rod type



22 Guided rod & stopper type



23 Rotary table



24 Grippers & EOAT for collaborative robots



25 Controllers for step motor



26 Controllers for AC servo motor



## 27 Our support network

## Stopper

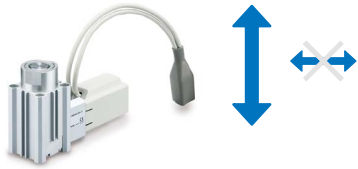

### Lateral travel prevention

Stop or redirect objects on conveyor lines by vertical movement and side impact resistance.

## Guided rod type

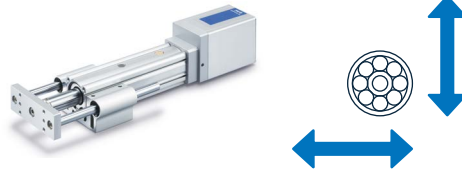

### Side load supported travel

Integrated bearings ensure that side loads are supported and do not compromise the actuator integrity. Additional, external guides are no longer required.

## Rod type

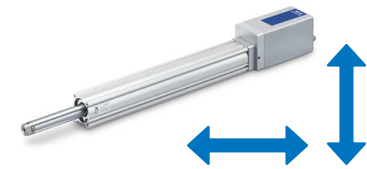

### Push and pull motion

Lifting, pushing, pressing or clamping. Rod type actuators are usually fixed to machinery at the rod end using interface brackets and joints. Side loads should be managed by supplementary external guides.

# Motor driven movement control for any application

SMC offers electric actuators for both linear or rotational movement. Movements can be guided, parts pressed, lifted, gripped, or clamped.

## Slide table



### Precision positioning

Enable guided linear transfer with enhanced stability. Guarantee precise and reliable motion along a defined distance.

## Slider type



### Long-distance transfer

Achieve precise and repeatable linear transfer. Ensure accuracy, repeatability and smooth motion for everyday parts positioning.

## Grippers & EOAT for collaborative robots

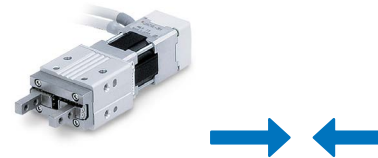

### Finger control

Enable safe and versatile gripping for conventional and collaborative applications. Handle differing shapes of component by selecting various jaw types.

## Rotary table



### Movement through 360°

Change the orientation of parts or components through multiple position stops or even create continuous rotation.

# Motor type

Like movement type, electrical actuator motor choice is generally related to the application's specific demands:

- **Payload**
- **Transfer speed**
- **Work duty**
- **Control flexibility.**

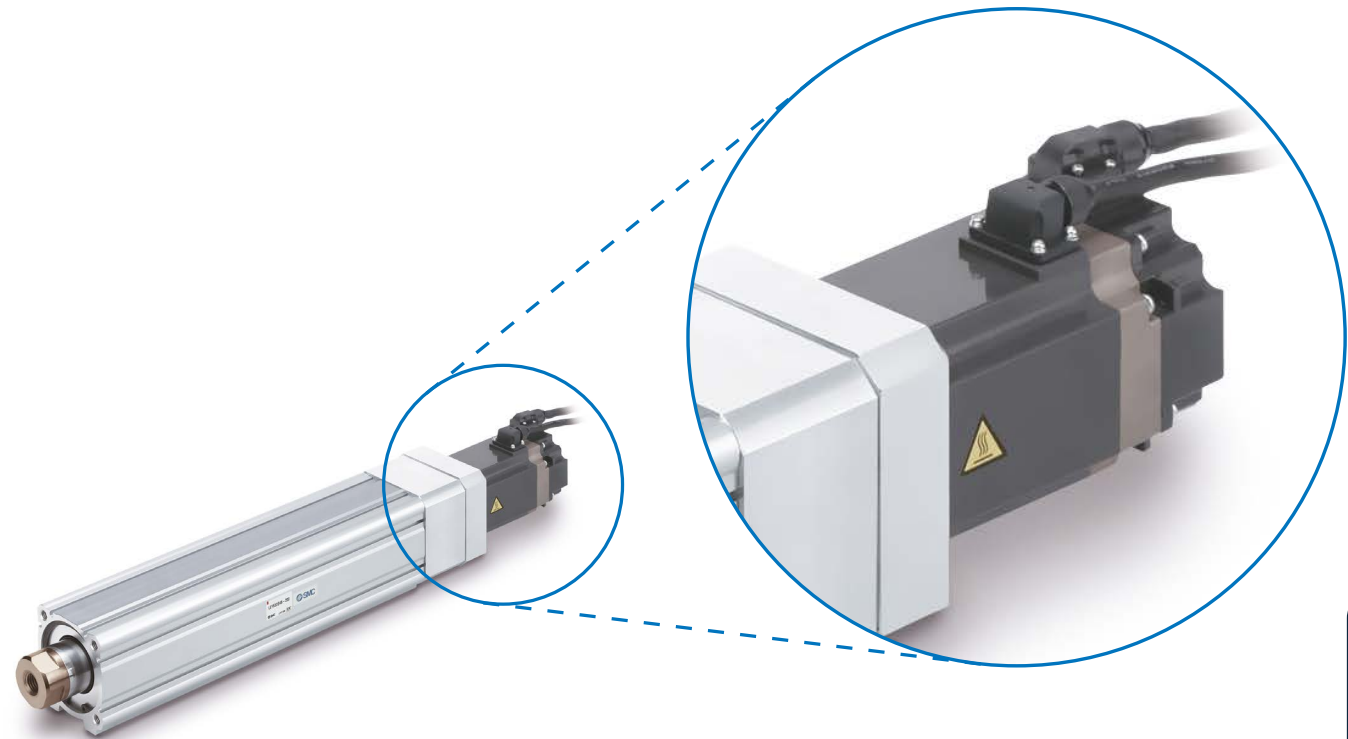

## Motorless (without motor)

The choice in applications where users want greater flexibility in motor and controller selection. Motorless actuators are often considered ideal when integrating new actuators into an existing system.

## AC servo

Excellent performance for movement of those heavier workloads at higher speeds or where higher dynamic performance also requires precise and fine control positioning.

## DC stepper

Stepper motors offer a more economical solution and basic parameter control. They are ideal in applications with lower demands on dynamic performance (speed or torque requirements).

SMC's range of DC stepper motors incorporate batteryless absolute encoders and offer similar repeatability to that of AC servos.

# Controller type

The motor controller selection can depend on several variables. Among the most important are:

- **Motor type**
- **Application demands (speed and torque, number of axis, available space)**
- **User programming experience and flexibility.**

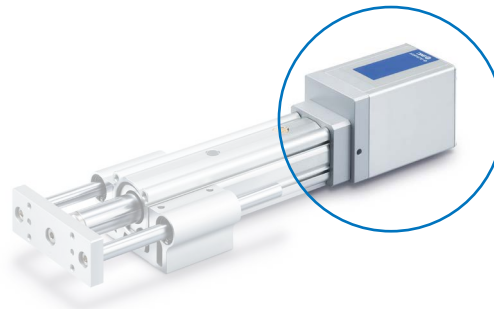

## Integrated

A combined controller, actuator, and motor all in one. No programming is necessary making it the optimal solution for more basic control applications not requiring more than 3 stop positions.



## Chassis system (manifold)

Multiple actuators and axis can be managed from a single place where a several compact slot mounted controllers are conveniently located side by side with other electrical switchgear to save on space.



## Individual (single axis)

Ideal for managing the movement and positioning of an actuator working independently. Operation is initiated by a host PLC selecting from stored parameter data. Such data is finite so more suited to basic and repeated control.



## Multi axis

Ideal choice when up to 3 actuators are required to work in relation to one another. Multi axis controllers save both mounting space and demands on wiring.

# Key trends

## Wireless integration with electric actuators



### Customer problem

Running control cables to every actuator can quickly become a headache, especially where tooling moves, stations change, or layouts evolve.

Now, picture controlling your electric actuators safely and reliably without a need for any control wiring, even at distances of up to 100 metres.

This communication is secure, reliable and noise-free using frequency hopping and data encryption for peace of mind.

### INCREASE

- Tool changing efficiency
- Flexible manufacturing
- Access to harsh environments.

### REDUCE

- Initial wiring time
- Risk of cable damage
- Impact of electrical noise
- Mechanical problems associated with repeated connection / disconnection
- Costs of cables
- Demands on mechanical slip rings.



### Application example

Automated lines using multiple EQFS electric actuators can be installed and repositioned with ease.

With an integrated controller and a battery-less absolute encoder, each actuator retains its position even after power loss, ensuring reliable and efficient operation from the start.

# e-Actuator

## Customer problem

In many production environments, integrating electric actuators can be cumbersome, extensive wiring, complex programming, and frequent adjustments slow down tool changes, reconfiguration and flexible manufacturing.

## Solution

SMC's EQ electric actuators come with an integrated controller built-in: just connect power and signal cables, set your movement parameters and you're ready to go. The EQ electric actuator range suits users that, up to now consider electric actuators too complex for their needs. They have been developed with ease of setup and control in mind.

## Why this matters for you

- Plug-and-play setup, fewer cables, fewer components, less commissioning time
- Built-in battery-less absolute encoder, accurate positioning and no return-to-origin needed after power off
- Multiple motion modes offers movement control of up to 3 stop positions without a need to input complexed parameter data
- High performance, with speeds up to 1200 mm/s and loads up to 100 kg
- Energy savings and sustainability through motor control optimisation, reducing annual CO<sub>2</sub> emissions.

[+ Discover more](#)

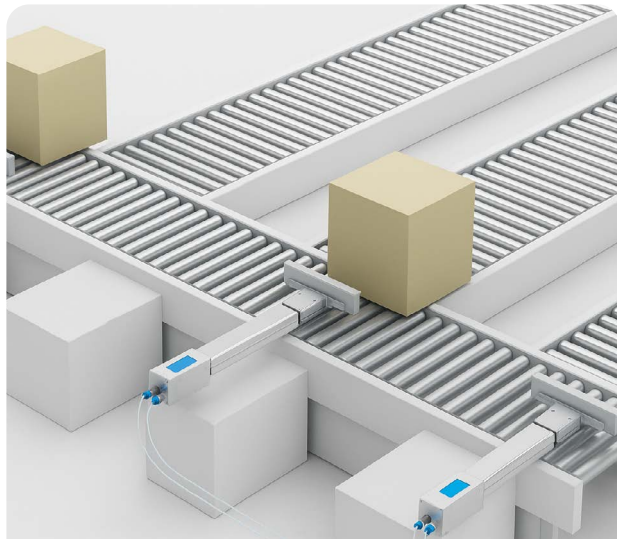

## Application example

Imagine a modular assembly station where you need a linear slide to move parts smoothly between positions. With the EQ series, you simply set the stroke, define your end points and, if required add a mid-position stop and you're ready to run. If the layout changes later, just adjust or replace the stroke length; the integrated controller keeps your settings stored.

Even in the event of power loss, the actuator can hold its position, keeping your part exactly where it should be. An optional safety lock adds extra peace of mind when precision and protection matter most.

And what makes it truly stand out is that it is intuitive, quick to set up, and effortless to operate. Motion control doesn't have to be complicated.



## IO-Link

Bring your production to the next level with EQ series actuators featuring IO-Link communication.

**This open, standardised interface connects your actuators directly to upper-level equipment, allowing you to set parameters, monitor performance, and perform predictive maintenance, all in real time.**

## Key benefits

- **Connect it, start it up and control it easily** – Electric actuator and controller, all in one. Complete setup in just three steps. Easy on/off operation.
- **Battery-less absolute encoder** – Restart from the last position. High performance.
- **Lower your CO<sub>2</sub> emissions** – Motor optimisation with reduced heat generation and power consumption.
- **Reduce maintenance while improving performance** – M12 connectors. Only three cables needed.

# Manifold controller

Instant actuator recognition means no parametrisation is needed, making replacement faster and easier than ever.

## Compact control. Smarter performance.

When every millimetre matters, the JXD1 series delivers big performance in a small footprint. Its sleek, fanless design keeps your cabinet compact, uncluttered and sits conveniently alongside other electrical switchgear.

## All connections. One direction.

Every cable, connector and port is accessible from the front. Installation, inspection, and replacement is faster than ever, keeping your line up and running with minimal effort.

## One controller. Multiple actuator types.

The manifold controller is designed to drive a full range of electric actuators: slider type, rod type, guide rod type and rotary table.

Coordinate up to 16 axes with one manifold controller, ensuring motion throughout your process.

## Speak every industrial language

With built-in compatibility for CC-Link, EtherNet/IP™, EtherCAT® and PROFINET®, integration into an existing system is seamless. Whatever your network, the JXD1 connects with ease.

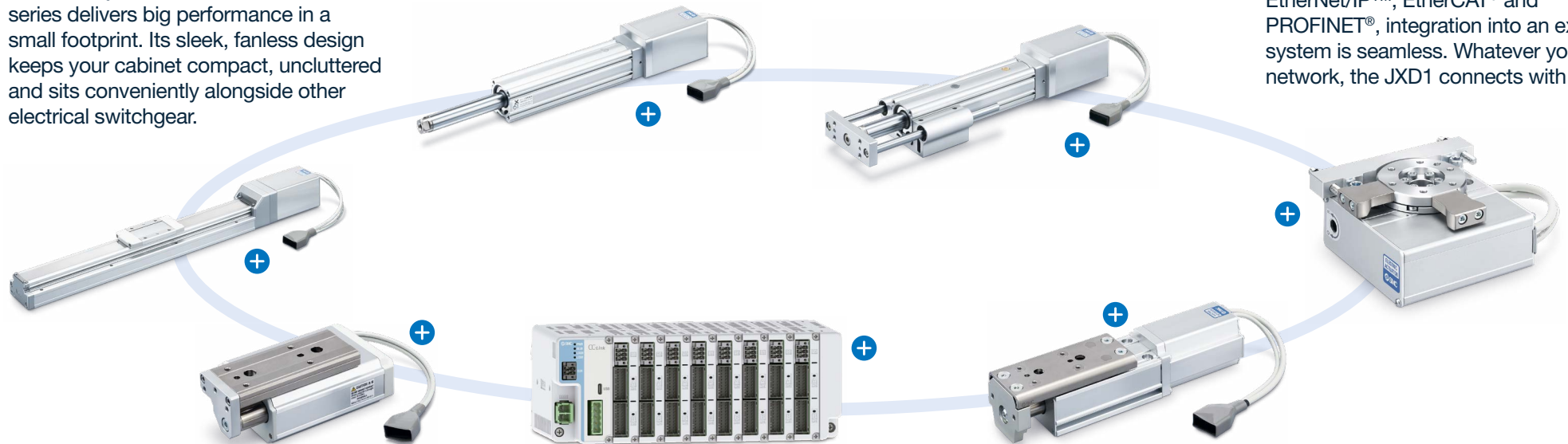

## Space-saving design for smarter panels

Every module fits perfectly together, reducing wiring clutter and freeing up valuable cabinet space. More performance, less complexity.

# Electric actuators with improved ingress protection

## Reliable motion in any environment

Engineered for automation environments where cleanliness, durability and precision are essential. These electric actuators perform reliably across industries such as food and beverage, pharmaceuticals, packaging, assembly, and general manufacturing, providing smooth, accurate motion even under challenging environmental conditions.

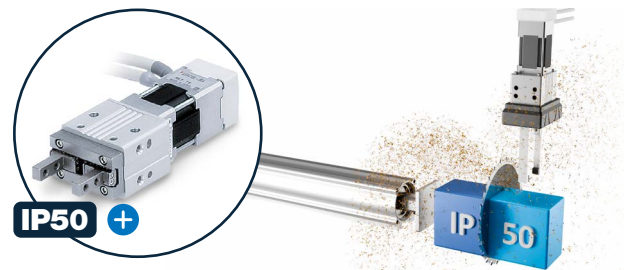

### Energy-efficient and clean

All-electric motion eliminates demands for compressed air, reducing noise, leaks and potential contamination.

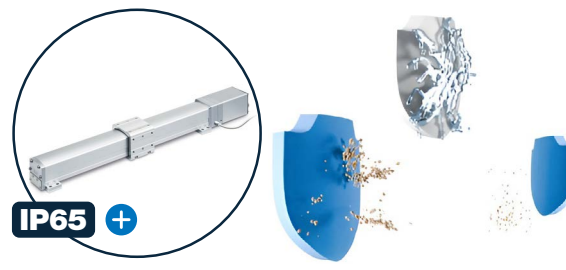

### Comprehensive environmental protection

Options available from IP50 to IP69K to suit dusty, humid or washdown environments.

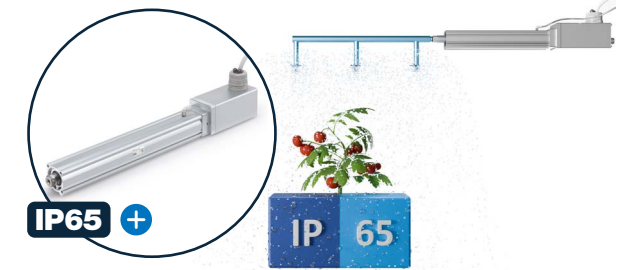

### Consistent performance

Stable operation under variations in temperature, dust exposure or moisture contact.

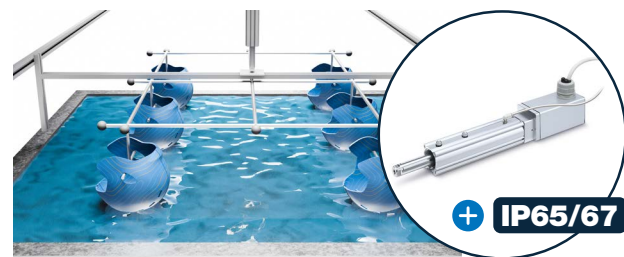

### Reliable sealing technology

Advanced sealing materials and construction ensure long-term protection against dust, moisture and cleaning agents.



### Compact and modular design

Multiple configurations – rod, slider, and gripper – adapt easily to diverse demands.



### Easy integration

Compatible with a wide range of controllers and automation systems for a seamless setup.

# Controllers with STO functionality

## Broader & safer control

### Safe and reliable control with Safe Torque Off (STO)

Keep your machines running safely and dependably with the **JXC□F+** & **LECS+** controllers. It delivers smooth, consistent motion while providing built-in protection providing built-in protection for the actuator whenever safety is required. The Safe Torque Off (STO) function cuts motor power to prevent unintended movement during setup, maintenance or emergency stops, giving you confidence, reliability and peace of mind every time you press start.

---

**Because smart control isn't just about performance – it's about protecting what matters most.**

---

- **Achieve** compliance with SIL3 / PLe safety standards
- **Control** every motion precisely – sliding, pushing, lifting or rotating
- **Connect** easily to your existing network setup
- **Simplify** installation with no extra safety control modules or complex wiring
- **Protect** operators working close to moving parts.

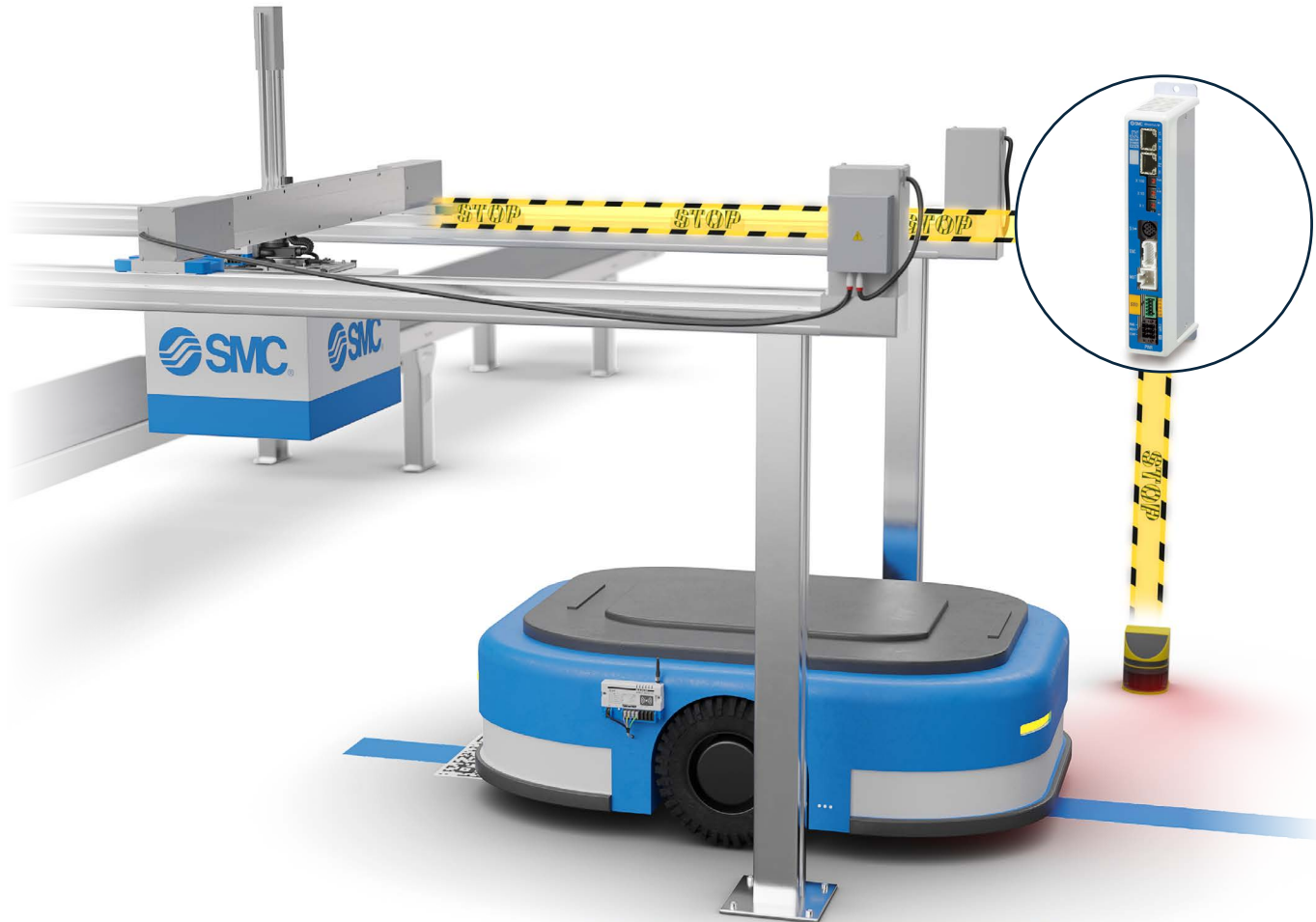

# LEA multi-axis system mounting kit

## Design your own motion

Whether you're constructing a 2-axis system, a 3-axis cantilever or a full X-Y-Z gantry, the LEA mounting kit gives you the foundation to build it with speed and reliability. It includes plates, boom profiles, pins and screws – everything you need to configure actuators into a multi-axis system and get your motion solution up and running.

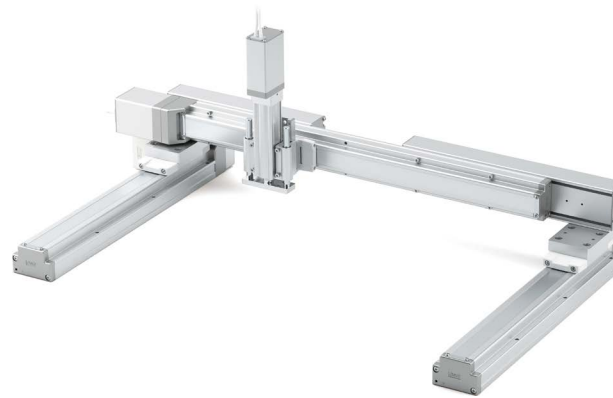

- Assemble a 2- or 3-axis system with ease using the kit's modular components
- Combine sliders, guided rods and rotary axes for flexible mechanical motion, ready for any layout
- Design with confidence using the online model-selection software to choose actuators, strokes and size combinations
- Reduce custom design, fabrication, mounting complexity and setup time by using a standardised kit.

## Multi-axis system software

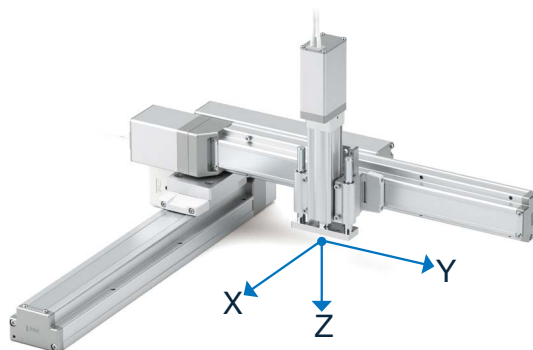

## Smart selection. Less time, more motion.

Choosing the right components for a multi-axis system can be time-consuming. With SMC's dedicated configuration software, customers can automatically identify the correct part numbers for their LEA mounting setup, removing guesswork and speeding up the selection process. Build your system faster, with confidence and accuracy.

**+ Electric actuator software**

## SUCCESS STORY

### Smarter multi-axis assembly with LEA mounting kits

#### Challenge

A packaging equipment manufacturer needed to align multiple electric actuators in a compact space to handle fast product changeovers. Traditional custom brackets were heavy, time-consuming to assemble and lacked flexibility when reconfiguring the system.

#### Solution

By introducing SMC's LEA mounting kit for multi-axis systems, the engineering team could quickly align several LE series actuators (slider and rod types) with high precision. The modular brackets allowed effortless positioning and easy re-adjustment when changing production formats.

#### Results

- Installation time reduced
- Easier reconfiguration between product batches
- Improved rigidity and alignment accuracy
- Compact, clean design compatible with collaborative setups.

# Electric actuators with absolute encoder

Benefit from SMC's comprehensive range of actuators with built in absolute encoders to ensure:

- No homing necessary
- High resolution with accurate positional feedback
- Reduced downtime
- Reliable position recognition for safety critical movements.

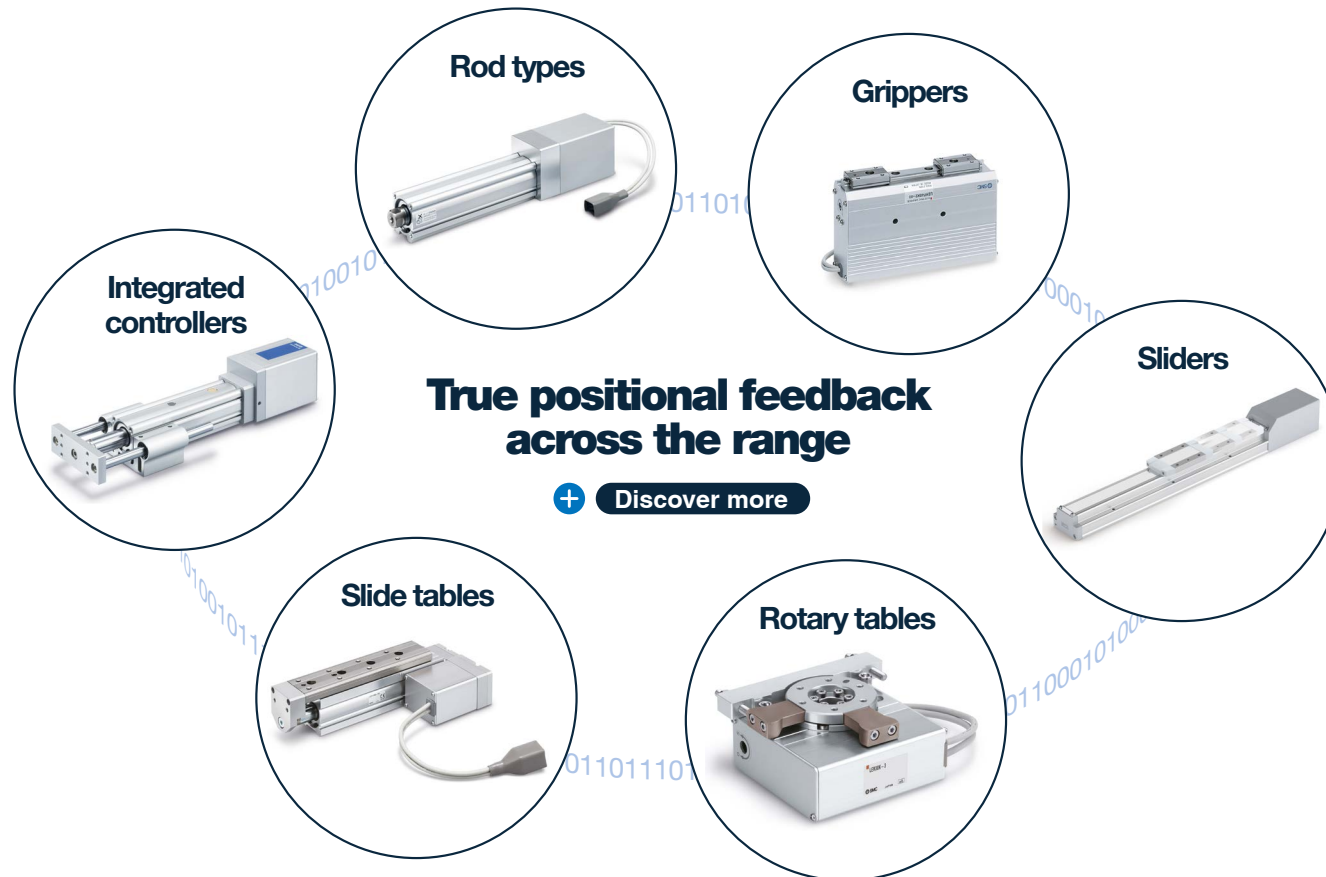

## Application example

Customers using high speed automated palletising machinery regularly suffered serious downtime and productivity problems after power losses or emergency stops. Equipment using motor driven actuators with incremental encoders require slow speed homing before normal operation can commence.

Integrating SMC's absolute encoder electric actuators means operation can commence where the process left off. Re-start time is now instant and reliable.

# Teaching box

## Portable operator unit – JX-T1 series

### No PC? No problem!

Setup and monitor your electric actuators without the reliance on a PC or laptop. No complex or sophisticated software, just a portable, robust and dedicated control box making commissioning and maintenance convenient.

### Key benefits

- **Save time** – teach, adjust and verify movements instantly on site
- **Work freely** – powered directly from the controller, no external power source required
- **Connect easily** – switch between actuators just by changing the cable
- **Simplify maintenance and fault finding** – monitor control and review and alarm signals.



### EQ actuators

Motor driven movement with integrated controller.

Touchscreen setup and monitor different controller types



### JXC Series

Separate controller and electric actuator.

# Collaborative robots

## Collaborative robots that move with you

When people and robots share the same workspace, every detail matters. SMC's range of components for collaborative robots helps you design smarter, safer and more adaptable automation cells. From lightweight electric actuators to soft gripping solutions and compact mounting kits, everything is engineered to make your cobot more capable – and your production more efficient.

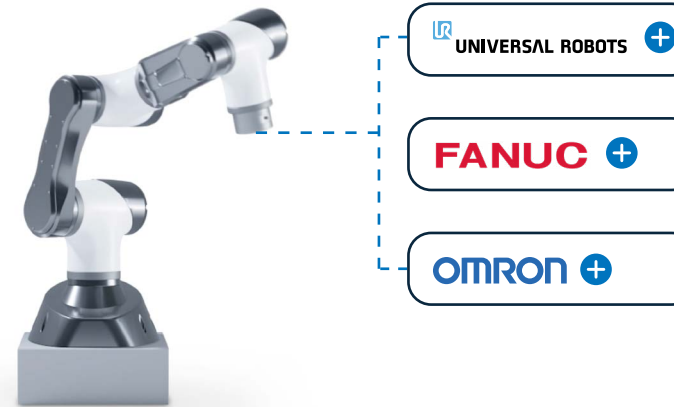

- **Simplify your setup** – modular, plug-and-play components ready for quick integration
- **Work safely together** – smooth, low-impact motion and certified safety functions protect operators
- **Maximise flexibility** – adapt your cobot for different tasks: pick, place, assemble or test
- **Save energy and space** – compact, lightweight solutions that reduce power consumption
- **Increase uptime** – robust, low-maintenance design keeps your cobot running longer
- **Accelerate ROI** – faster commissioning and reduced changeover time mean quicker payback.



### Quick and safe tool change for collaborative robots

Reduce setup time and design complexity with the **RMTM +** manual tool changer. It mounts directly on collaborative robots allows tool exchange in seconds. With high rigidity,  $\pm 0.01$  mm repeatability, it's the perfect match for your electric gripper when flexibility matters most.

# Everything you need in one place

+ Ask our experts

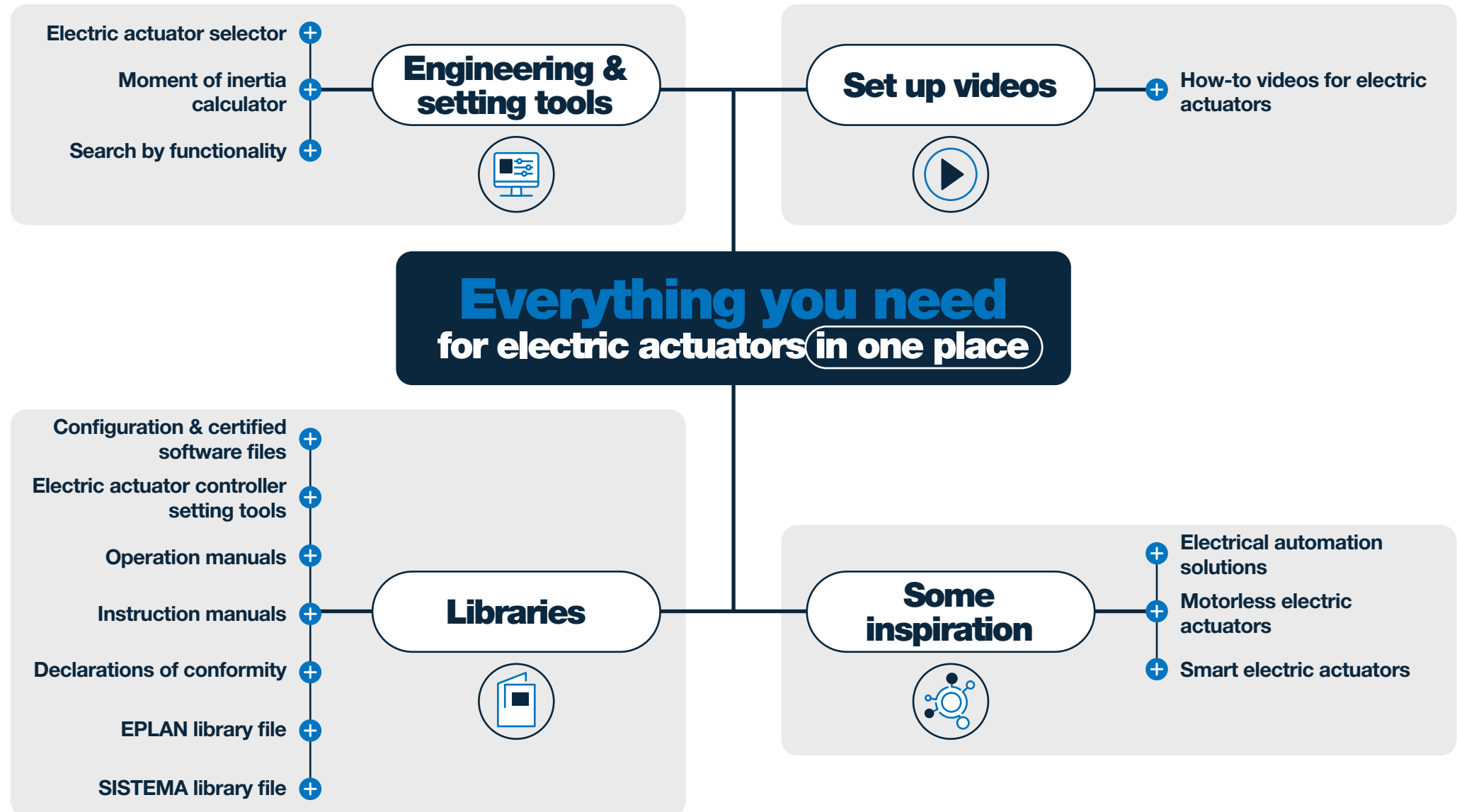



# Slider type

| Series          | Feature                                                                | Motor type          |                          |           | Stroke range [mm] |     |     |     |     |     |      | Workload [kg] <sup>1)</sup> |    |    |    |    |     |     | Speed [mm/s] |
|-----------------|------------------------------------------------------------------------|---------------------|--------------------------|-----------|-------------------|-----|-----|-----|-----|-----|------|-----------------------------|----|----|----|----|-----|-----|--------------|
|                 |                                                                        | Step motor (24 VDC) | AC servo motor (230 VAC) | Motorless | 50                | 100 | 200 | 300 | 400 | 500 | 1000 | 1500                        | 20 | 40 | 60 | 80 | 100 | 200 |              |
| <b>EQFS</b>     | Integrated controller & absolute encoder                               | +                   | -                        | -         | [Shaded]          |     |     |     |     |     |      | [Shaded]                    |    |    |    |    |     |     | 1200         |
| <b>LEFS</b>     | Standard type                                                          | +                   | +                        | +         | [Shaded]          |     |     |     |     |     |      | [Shaded]                    |    |    |    |    |     |     | 1500         |
| <b>LEFS□E</b>   | Absolute encoder                                                       | +                   | -                        | -         | [Shaded]          |     |     |     |     |     |      | [Shaded]                    |    |    |    |    |     |     | 1200         |
| <b>LEFS□F</b>   | High performance                                                       | +                   |                          |           | [Shaded]          |     |     |     |     |     |      | [Shaded]                    |    |    |    |    |     |     |              |
| <b>LEFS□G</b>   | High performance with absolute encoder                                 | +                   |                          |           | [Shaded]          |     |     |     |     |     |      | [Shaded]                    |    |    |    |    |     |     |              |
| <b>LEKFS</b>    | High rigidity and high precision with absolute encoder                 | +                   | +                        | +         | [Shaded]          |     |     |     |     |     |      | [Shaded]                    |    |    |    |    |     |     | 1500         |
| <b>LEKFS□G</b>  | High rigidity and high performance with absolute encoder               | +                   | -                        | -         | [Shaded]          |     |     |     |     |     |      | [Shaded]                    |    |    |    |    |     |     | 1200         |
| <b>LE2FS□H</b>  | Absolute encoder type for use with chassis mount (manifold) controller | +                   |                          |           | [Shaded]          |     |     |     |     |     |      | [Shaded]                    |    |    |    |    |     |     |              |
| <b>LEFSW</b>    | Dust/drip proof, IP65 with absolute encoder                            | +                   |                          |           | [Shaded]          |     |     |     |     |     |      | [Shaded]                    |    |    |    |    |     |     |              |
| <b>11-LEFS</b>  | Clean room compatible                                                  | +                   | +                        | -         | [Shaded]          |     |     |     |     |     |      | [Shaded]                    |    |    |    |    |     |     | 1000         |
| <b>25A-LEFS</b> | Secondary battery process compatible                                   | +                   |                          |           | [Shaded]          |     |     |     |     |     |      | [Shaded]                    |    |    |    |    |     |     | 1500         |
| <b>LEJS</b>     | High speed, high rigidity type                                         | -                   |                          |           | [Shaded]          |     |     |     |     |     |      | [Shaded]                    |    |    |    |    |     |     | 2300         |
| <b>11-LEJS</b>  | Clean room compatible                                                  | -                   | +                        | +         | [Shaded]          |     |     |     |     |     |      | [Shaded]                    |    |    |    |    |     |     | 1200         |
| <b>25A-LEJS</b> | Secondary battery process compatible                                   | -                   | +                        | -         | [Shaded]          |     |     |     |     |     |      | [Shaded]                    |    |    |    |    |     |     | 1800         |

1) ■ Horizontal workload.  
■ Vertical workload.



EQ Series



LEFS Series



LEFSW Series



LEJS Series

# Slide table

| Series  | Feature                                                  | Motor type          |                       |                          |                       | Stroke range [mm]     |    |                       |    |    |     |     |     |     |                     | Workload [kg] <sup>1)</sup> |   |                     |    |    | Pushing force [N] | Speed [mm/s] | Positioning repeatability [mm] |     |       |
|---------|----------------------------------------------------------|---------------------|-----------------------|--------------------------|-----------------------|-----------------------|----|-----------------------|----|----|-----|-----|-----|-----|---------------------|-----------------------------|---|---------------------|----|----|-------------------|--------------|--------------------------------|-----|-------|
|         |                                                          | Step motor (24 VDC) | Linear motor (24 VDC) | AC servo motor (230 VAC) | Motorless             | 10                    | 20 | 30                    | 40 | 50 | 100 | 120 | 130 | 140 | 150                 | 2                           | 6 | 10                  | 14 | 18 |                   |              |                                | 22  |       |
| LES     | Standard type                                            | +                   | -                     | -                        | -                     | [Horizontal workload] |    |                       |    |    |     |     |     |     |                     | [Vertical workload]         |   |                     |    |    | 180               | 400          | ±0.05                          |     |       |
| LES□E   | Absolute encoder                                         | +                   |                       |                          |                       |                       |    |                       |    |    |     |     |     |     |                     |                             |   |                     |    |    |                   |              |                                |     |       |
| LESH    | High rigidity                                            | +                   |                       |                          |                       |                       |    |                       |    |    |     |     |     |     |                     |                             |   |                     |    |    |                   |              |                                |     |       |
| LESH□E  | High rigidity with absolute encoder                      | +                   |                       |                          |                       |                       |    |                       |    |    |     |     |     |     |                     |                             |   |                     |    |    |                   |              |                                |     |       |
| LESYH   | High precision with absolute encoder                     | +                   |                       |                          |                       | +                     | +  | [Horizontal workload] |    |    |     |     |     |     |                     |                             |   | [Vertical workload] |    |    |                   |              | 420                            | 800 | ±0.01 |
| LESYH□G | High rigidity and high performance with absolute encoder | +                   |                       |                          |                       |                       |    |                       |    |    |     |     |     |     |                     |                             |   |                     |    |    |                   |              |                                |     |       |
| LEPS    | Miniature type                                           | +                   |                       |                          |                       | -                     | -  | [Horizontal workload] |    |    |     |     |     |     |                     |                             |   | [Vertical workload] |    |    |                   |              | 50                             | 350 | ±0.05 |
| LAT3    | Card motor                                               | -                   | +                     | -                        | [Horizontal workload] |                       |    |                       |    |    |     |     |     |     | [Vertical workload] |                             |   |                     |    | 3  | 400               | ±0.005       |                                |     |       |

1) ■ Horizontal workload.  
■ Vertical workload.



LAT3 Series



LES Series



LESYH Series



LEPS Series

# Rod type

| Series   | Feature                                                                | Motor type          |                          |                       | Stroke range [mm]     |    |     |     |                       |                       | Workload [kg] <sup>1)</sup> |    |    |      |      | Pushing force [N] | Speed [mm/s] |
|----------|------------------------------------------------------------------------|---------------------|--------------------------|-----------------------|-----------------------|----|-----|-----|-----------------------|-----------------------|-----------------------------|----|----|------|------|-------------------|--------------|
|          |                                                                        | Step motor (24 VDC) | AC servo motor (230 VAC) | Motorless             | 20                    | 60 | 100 | 250 | 500                   | 750                   | 1000                        | 10 | 30 | 50   | 70   |                   |              |
| EQY      | Integrated controller & absolute encoder                               | +                   | -                        | -                     | [Horizontal workload] |    |     |     |                       |                       | [Horizontal workload]       |    |    |      |      | 796               | 900          |
| LEY      | Standard type                                                          | +                   | +                        | +                     | [Horizontal workload] |    |     |     |                       |                       | [Horizontal workload]       |    |    |      |      | 12000             | 1200         |
| LEY□E    | Absolute encoder                                                       | +                   | -                        | -                     | [Horizontal workload] |    |     |     |                       |                       | [Horizontal workload]       |    |    |      |      | 1058              | 500          |
| LEY□F    | High performance                                                       | +                   |                          |                       | [Horizontal workload] |    |     |     |                       |                       | [Horizontal workload]       |    |    |      |      |                   | 800          |
| LEY□G    | High performance with absolute encoder                                 | +                   |                          |                       | [Horizontal workload] |    |     |     |                       |                       | [Horizontal workload]       |    |    |      |      |                   |              |
| LE2Y□H   | Absolute encoder type for use with chassis mount (manifold) controller | +                   |                          |                       | [Horizontal workload] |    |     |     |                       |                       | [Horizontal workload]       |    |    |      |      | 796               | 900          |
| LEY-X5   | IP65 enclosure                                                         | +                   | +                        | -                     | [Horizontal workload] |    |     |     |                       |                       | [Horizontal workload]       |    |    |      |      | 736               | 1200         |
| LEY-X7   | IP67 enclosure                                                         | +                   | [Horizontal workload]    |                       |                       |    |     |     | [Horizontal workload] |                       |                             |    |    | 1058 | 400  |                   |              |
| LEY-X8   | IP67 enclosure with absolute encoder                                   | +                   | [Horizontal workload]    |                       |                       |    |     |     | [Horizontal workload] |                       |                             |    |    |      |      |                   |              |
| HF2A-LEY | IP69K enclosure                                                        | -                   | +                        |                       | [Horizontal workload] |    |     |     |                       |                       | [Horizontal workload]       |    |    |      |      | 1910              | 1200         |
| 25A-LEY  | Secondary battery process compatible                                   | +                   | +                        | [Horizontal workload] |                       |    |     |     |                       | [Horizontal workload] |                             |    |    |      | 1058 | 800               |              |
| L(D)ZB   | Basic                                                                  | +                   | -                        | -                     | [Horizontal workload] |    |     |     |                       |                       | [Horizontal workload]       |    |    |      |      | -                 | 200          |
| LEPY     | Miniature rod type                                                     | +                   |                          |                       | [Horizontal workload] |    |     |     |                       |                       | [Horizontal workload]       |    |    |      |      | 50                | 350          |

1) ■ Horizontal workload.  
■ Vertical workload.



EQY Series



LEY Series



HF2A-LEY Series



LEPY Series

# Guided rod & stopper type

| Series   | Feature                                                                | Motor type          |                          |           | Stroke range [mm] |    |     |     |     | Workload [kg] <sup>1)</sup> |    |    |    |      | Pushing force [N] | Speed [mm/s] | Product weight [kg] |
|----------|------------------------------------------------------------------------|---------------------|--------------------------|-----------|-------------------|----|-----|-----|-----|-----------------------------|----|----|----|------|-------------------|--------------|---------------------|
|          |                                                                        | Step motor (24 VDC) | AC servo motor (230 VAC) | Motorless | 20                | 60 | 100 | 200 | 300 | 10                          | 30 | 50 | 70 | 90   |                   |              |                     |
| LEBQ-X1  | Ball screw stopper controlled by separate driver                       | +                   |                          |           | ■                 |    |     |     |     |                             |    |    |    |      |                   | 135          | 1.99                |
| LEBQ-X31 | Ball screw stopper. No controller required.                            | +                   |                          |           | ■                 |    |     |     |     |                             |    |    |    |      | —                 | —            | 2.60                |
| LEBH-X3  | Ball screw stopper. No controller required. Flange mounted.            | +                   | —                        | —         | ■                 |    |     |     |     |                             |    |    |    |      |                   |              | 9.30                |
| EQYG     | Guide rod. Integrated controller & absolute encoder.                   | +                   |                          |           | ■                 | ■  | ■   | ■   | ■   | ■                           | ■  | ■  | ■  | ■    | 796               | 900          | 6.53                |
| LEYG     | Guide rod. Standard type.                                              | +                   | +                        | +         | ■                 | ■  | ■   | ■   | ■   | ■                           | ■  | ■  | ■  | 1200 | 500               | —            |                     |
| LE2YG    | Absolute encoder type for use with chassis mount (manifold) controller | +                   |                          |           | ■                 | ■  | ■   | ■   | ■   | ■                           | ■  | ■  | ■  | 796  | 900               | —            |                     |
| LEG      | Guide rod. High rigidity and high performance with absolute encoder.   | +                   | —                        | —         | ■                 | ■  | ■   | ■   | ■   | ■                           | ■  | ■  | ■  | 553  | 250               | —            |                     |
| L(D)ZC   | Basic                                                                  | +                   |                          |           | ■                 | ■  | ■   | ■   | ■   |                             |    |    |    | 196  | 200               | 2.38         |                     |

1) ■ Horizontal workload.  
■ Vertical workload.

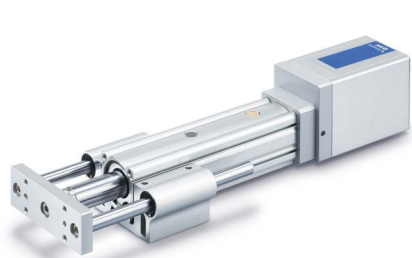

EQYG Series



LEYG Series



LEG Series



LEBQ-X1 Series

# Rotary table

| Series | Feature                                                                | Motor type          | Lead range [°] |   |   |   |   |    | Angular speed [°/s] | Rotation angle [°] | Pushing speed [°/s] | Positioning repeatability [mm] |
|--------|------------------------------------------------------------------------|---------------------|----------------|---|---|---|---|----|---------------------|--------------------|---------------------|--------------------------------|
|        |                                                                        | Step motor (24 VDC) | 1              | 3 | 5 | 7 | 9 | 11 |                     |                    |                     |                                |
| LER    | Standard type                                                          | +                   |                |   |   |   |   |    | 420                 | 320                | 30                  | ±0.03                          |
| LER□E  | Absolute encoder                                                       | +                   |                |   |   |   |   |    |                     |                    |                     |                                |
| LE2R   | Absolute encoder type for use with chassis mount (manifold) controller | +                   |                |   |   |   |   |    | 600                 |                    |                     |                                |



LER Series



LER□E Series



LE2R Series

# Grippers & EOAT for collaborative robots

|                                           | Series   | Feature                                     | Motor type          | Open and close stroke [mm] |    |    |    |    |    |    |    | Gripping force [N] |    |    |     |     |     | Maximum lead [mm] | Repeatability [mm] | Positioning repeatability [mm] | Repeated length measurement accuracy [mm] |          |  |  |  |  |  |
|-------------------------------------------|----------|---------------------------------------------|---------------------|----------------------------|----|----|----|----|----|----|----|--------------------|----|----|-----|-----|-----|-------------------|--------------------|--------------------------------|-------------------------------------------|----------|--|--|--|--|--|
|                                           |          |                                             | Step motor (24 VDC) | 10                         | 20 | 30 | 40 | 50 | 60 | 70 | 80 | 30                 | 60 | 90 | 120 | 150 | 180 |                   |                    |                                |                                           | 210      |  |  |  |  |  |
| Gripper                                   | LEHZ     | 2 fingers, standard                         | +                   | [Shaded]                   |    |    |    |    |    |    |    | [Shaded]           |    |    |     |     |     | 242/39            | ±0.02              | ±0.05                          | ±0.05                                     |          |  |  |  |  |  |
|                                           | LEHZJ    | 2 fingers, standard with dust cover         | +                   | [Shaded]                   |    |    |    |    |    |    |    | [Shaded]           |    |    |     |     |     | 243/48            |                    |                                |                                           |          |  |  |  |  |  |
|                                           | LEHF     | 2 finger wide opening                       | +                   | [Shaded]                   |    |    |    |    |    |    |    | [Shaded]           |    |    |     |     |     | 70/16             | ±0.05              | ±0.01                          |                                           |          |  |  |  |  |  |
|                                           | LEHF#E   | 2 finger wide opening with absolute encoder | +                   | [Shaded]                   |    |    |    |    |    |    |    | [Shaded]           |    |    |     |     |     |                   |                    |                                |                                           |          |  |  |  |  |  |
|                                           | LEHS     | 3 fingers, standard                         | +                   | [Shaded]                   |    |    |    |    |    |    |    | [Shaded]           |    |    |     |     |     | 255/76            | ±0.02              | ±0.05                          |                                           |          |  |  |  |  |  |
| Electric gripper for collaborative robots | LEHR-011 | For UR collaborative robots                 | +                   | 50                         |    |    |    |    |    |    |    | [Shaded]           |    |    |     |     |     | -                 | ±0.01              | ±0.01                          | -                                         |          |  |  |  |  |  |
|                                           | LEHR-051 | For Fanuc corporation collaborative robots  | +                   |                            |    |    |    |    |    |    |    | [Shaded]           |    |    |     |     |     |                   |                    |                                |                                           | [Shaded] |  |  |  |  |  |
|                                           | LEHR-021 | For Omron techman collaborative robots      | +                   |                            |    |    |    |    |    |    |    | [Shaded]           |    |    |     |     |     |                   |                    |                                |                                           | [Shaded] |  |  |  |  |  |

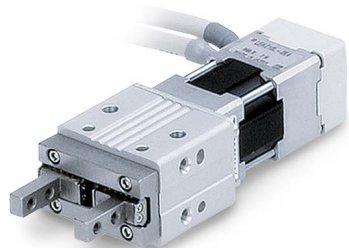

LEHZ Series



LEHF Series

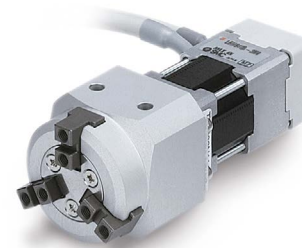

LEHS Series



LEHR Series

# Controllers for step motor



|                                           |  | Series                                             | Feature                                                             | Compatible motor                                                            |             | Encoder type |             | Blank controller | Parallel |        | Fieldbus compatibility                                           | Safe torque off                             |                                                |   |   |   |                                             |
|-------------------------------------------|--|----------------------------------------------------|---------------------------------------------------------------------|-----------------------------------------------------------------------------|-------------|--------------|-------------|------------------|----------|--------|------------------------------------------------------------------|---------------------------------------------|------------------------------------------------|---|---|---|---------------------------------------------|
|                                           |  |                                                    |                                                                     | Step motor                                                                  | Servo motor | Absolute     | Incremental |                  | Input    | Output |                                                                  |                                             |                                                |   |   |   |                                             |
| Digital I/O commanded controllers/drivers |  | JXC51/61                                           | Single axis, parallel I/O operations                                | +                                                                           | —           | ✓            | ✓           | ✓                | 11       | 13     | —                                                                | —                                           |                                                |   |   |   |                                             |
|                                           |  | JXC5H/6H                                           | Single axis, optimised for high-performance parallel I/O operations | +                                                                           | —           | ✓            | ✓           | ✓                | 11       | 13     |                                                                  |                                             |                                                |   |   |   |                                             |
|                                           |  | LATCA                                              | For card motor LAT3                                                 | —                                                                           | +           | —            | —           | —                | 6        | 4      |                                                                  |                                             |                                                |   |   |   |                                             |
|                                           |  | LC3                                                | LZ actuators only                                                   | —                                                                           | +           |              |             |                  | 3        | —      |                                                                  |                                             |                                                |   |   |   |                                             |
|                                           |  | LECPA                                              | Pulse input control of electric actuators                           | +                                                                           | —           | 5            | 9           |                  |          |        |                                                                  |                                             |                                                |   |   |   |                                             |
| Fieldbus commanded controllers/drivers    |  | DC fieldbus single-axis                            | JXCE1/91/P1/D1/L1/M1                                                | Control over industrial networks                                            | +           | —            | —           | ✓                | —        | —      | EtherCAT®, EtherNet/IP™, PROFINET®, DeviceNet®, IO-Link, CC-Link | —                                           |                                                |   |   |   |                                             |
|                                           |  |                                                    | JXCEH/9H/PH                                                         | High performance, over industrial networks                                  | +           |              |             |                  |          |        |                                                                  |                                             | —                                              | ✓ | — | — | EtherCAT®, EtherNet/IP™, PROFINET®          |
|                                           |  |                                                    | JXCEF/9F/PF/LF                                                      | High performance safety applications                                        | +           |              |             |                  |          |        |                                                                  |                                             | —                                              | — | — | — | EtherCAT®, EtherNet/IP™, PROFINET®, IO-Link |
|                                           |  | Manifold controller, battery-less absolute encoder | JXD1-M                                                              | Chassis mount (manifold) controller for up to 16 axes                       | +           | —            | —           | —                | —        | —      | —                                                                | EtherNet/IP™, CC-Link, EtherCAT & PROFINET® | —                                              |   |   |   |                                             |
|                                           |  |                                                    | JXC92                                                               | Simultaneous control of up to three axes                                    | +           |              |             |                  |          |        |                                                                  |                                             |                                                | — | ✓ | — | —                                           |
|                                           |  | DC fieldbus gateway                                | LEC-G                                                               | Connection of multiple controllers to fieldbus networks with minimal wiring | —           | +            | —           | —                | —        | —      | —                                                                | —                                           | EtherNet/IP™, DeviceNet®, CC-Link, PROFIBUS DP | — |   |   |                                             |

# Controllers for AC servo motor



| Series      | Feature                                                     | Motor type               | Encoder type |             | Parallel |        | Fieldbus compatibility                           | Safe torque off | Compatible motor [w] |     |     |     |
|-------------|-------------------------------------------------------------|--------------------------|--------------|-------------|----------|--------|--------------------------------------------------|-----------------|----------------------|-----|-----|-----|
|             |                                                             | AC servo motor (230 VAC) | Absolute     | Incremental | Input    | Output |                                                  |                 | 100                  | 200 | 400 | 750 |
| LECSA       | Control position or speed through simple pulse input        | +                        | –            | ✓           | 6        | 4      | –                                                | –               |                      |     |     | –   |
| LECS□(D)-T  | Control over fieldbus networks                              | +                        |              |             | –        | –      | EtherCAT®, EtherNet/IP™, PROFINET®, SSCNET III/H | ✓               |                      |     |     |     |
| LECSB-T     | Precise positioning with enhanced performance               | +                        | ✓            | –           | 10       | 6      | –                                                | –               | ✓                    | ✓   | ✓   | ✓   |
| LECS-C-T    | Designed for seamless connection and reliable communication | +                        |              |             | –        | –      | CC-Link                                          | –               |                      |     |     |     |
| LECYM/LECYU | MECHATROLINK-II or III communication                        | +                        |              |             |          |        | MECHATROLINK-II, MECHATROLINK-III                | ✓               |                      |     |     | –   |

# Our support network

## SMC's worldwide commitment

One of the things we do best at SMC is **being close to our customers**. Local support, on a global scale.

With support in over **500 locations** across **80 countries** and regions **worldwide**, our sales force of **7000 experts** maintains **close communication with customers**.

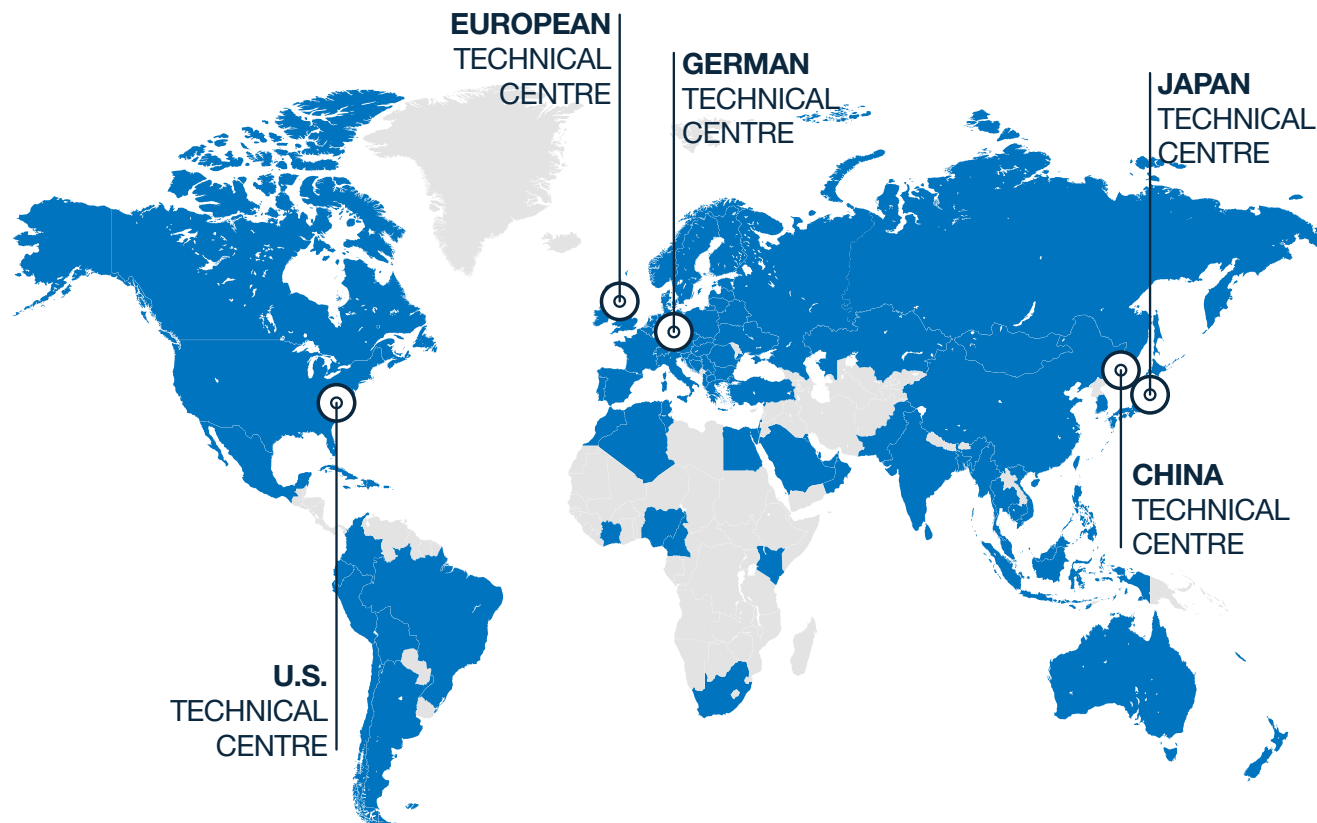

# SMC Business Continuity Plan

## Sustainable growth also means ensuring uninterrupted operations

We are committed to ensuring that SMC is prepared for any emergency and that our business activities will not stop in the event of such circumstances. SMC aims to fulfil our product supply responsibilities and maintain our customers' trust by contributing to both sustainable growth and the expansion of technological innovations.

SMC, as a comprehensive manufacturer of automatic control equipment that supports automation, is able to promptly provide products that meet our customers' needs anywhere in the world.

## Production BCP

### Ensure customer order fulfilment

Reliable delivery for you thanks to our 9 global logistic centres and 38 production sites worldwide. Moreover, flexibility to rapidly respond to any sudden change in the manufacturing environment.

## Finance BCP

### Safe & Solid financial base

In the event of an emergency, SMC can provide a safe and solid financial base (with cash, deposits, and equity capital) that will sufficiently cover the working capital and funds needed to rebuild buildings and the equipment required for business continuity. This is done to provide peace of mind to our customers and workers alike.

## Information security BCP

### Vital data kept safe

Strengthen information security for protection against computer viruses and cyberattacks, plus the installation of data centres to establish a disaster recovery system. Your information is safe with us.

## Engineering BCP

### Consistent technical support

2,000 engineers at our 5 technical centres around the globe.

## Sales BCP

### Consistent sales support

7,000 sales engineers worldwide ready to recommend the best solution for you. Over 80 global locations to make sure that wherever you are, we are there too.

[+ Discover more](#)



## SMC Corporation

1-5-5, Kyobashi,  
Chuo-ku, Tokyo  
104-0031, Japan  
Telephone: 03-6628-3000  
<https://www.smcworld.com>

|                       |                     |                                                                |                                                                        |  |  |  |  |  |  |
|-----------------------|---------------------|----------------------------------------------------------------|------------------------------------------------------------------------|--|--|--|--|--|--|
| <b>Austria</b>        | +43 (0)2262622800   | <a href="http://www.smc.at">www.smc.at</a>                     | <a href="mailto:office.at@smc.com">office.at@smc.com</a>               |  |  |  |  |  |  |
| <b>Belgium</b>        | +32 (0)33551464     | <a href="http://www.smc.be">www.smc.be</a>                     | <a href="mailto:info@smc.be">info@smc.be</a>                           |  |  |  |  |  |  |
| <b>Bulgaria</b>       | +359 (0)2807670     | <a href="http://www.smc.bg">www.smc.bg</a>                     | <a href="mailto:sales.bg@smc.com">sales.bg@smc.com</a>                 |  |  |  |  |  |  |
| <b>Croatia</b>        | +385 (0)13707288    | <a href="http://www.smc.hr">www.smc.hr</a>                     | <a href="mailto:sales.hr@smc.com">sales.hr@smc.com</a>                 |  |  |  |  |  |  |
| <b>Czech Republic</b> | +420 541424611      | <a href="http://www.smc.cz">www.smc.cz</a>                     | <a href="mailto:office.at@smc.com">office.at@smc.com</a>               |  |  |  |  |  |  |
| <b>Denmark</b>        | +45 70252900        | <a href="http://www.smc.dk.com">www.smc.dk.com</a>             | <a href="mailto:smc.dk@smc.com">smc.dk@smc.com</a>                     |  |  |  |  |  |  |
| <b>Estonia</b>        | +372 651 0370       | <a href="http://www.smcee.ee">www.smcee.ee</a>                 | <a href="mailto:info.ee@smc.com">info.ee@smc.com</a>                   |  |  |  |  |  |  |
| <b>Finland</b>        | +358 207513513      | <a href="http://www.smc.fi">www.smc.fi</a>                     | <a href="mailto:smc.fi@smc.com">smc.fi@smc.com</a>                     |  |  |  |  |  |  |
| <b>France</b>         | +33 (0)164761000    | <a href="http://www.smc-france.fr">www.smc-france.fr</a>       | <a href="mailto:supportclient.fr@smc.com">supportclient.fr@smc.com</a> |  |  |  |  |  |  |
| <b>Germany</b>        | +49 (0)61034020     | <a href="http://www.smc.de">www.smc.de</a>                     | <a href="mailto:info.de@smc.com">info.de@smc.com</a>                   |  |  |  |  |  |  |
| <b>Greece</b>         | +30 210 2717265     | <a href="http://www.smchellas.gr">www.smchellas.gr</a>         | <a href="mailto:sales@smchellas.gr">sales@smchellas.gr</a>             |  |  |  |  |  |  |
| <b>Hungary</b>        | +36 23513000        | <a href="http://www.smc.hu">www.smc.hu</a>                     | <a href="mailto:office.hu@smc.com">office.hu@smc.com</a>               |  |  |  |  |  |  |
| <b>Ireland</b>        | +353 (0)14039000    | <a href="http://www.smcautomation.ie">www.smcautomation.ie</a> | <a href="mailto:technical.ie@smc.com">technical.ie@smc.com</a>         |  |  |  |  |  |  |
| <b>Italy</b>          | +39 03990691        | <a href="http://www.smcitalia.it">www.smcitalia.it</a>         | <a href="mailto:mailbox.it@smc.com">mailbox.it@smc.com</a>             |  |  |  |  |  |  |
| <b>Latvia</b>         | +371 67817700       | <a href="http://www.smc.lv">www.smc.lv</a>                     | <a href="mailto:info.lv@smc.com">info.lv@smc.com</a>                   |  |  |  |  |  |  |
| <b>Lithuania</b>      | +370 5 2308118      | <a href="http://www.smclt.lt">www.smclt.lt</a>                 | <a href="mailto:info.lt@smc.com">info.lt@smc.com</a>                   |  |  |  |  |  |  |
| <b>Netherlands</b>    | +31 (0)205318888    | <a href="http://www.smc.nl">www.smc.nl</a>                     | <a href="mailto:info@smc.nl">info@smc.nl</a>                           |  |  |  |  |  |  |
| <b>Norway</b>         | +47 67129020        | <a href="http://www.smc-norge.no">www.smc-norge.no</a>         | <a href="mailto:post.no@smc.com">post.no@smc.com</a>                   |  |  |  |  |  |  |
| <b>Poland</b>         | +48 22 344 40 00    | <a href="http://www.smc.pl">www.smc.pl</a>                     | <a href="mailto:office.pl@smc.com">office.pl@smc.com</a>               |  |  |  |  |  |  |
| <b>Portugal</b>       | +351 214724500      | <a href="http://www.smc.eu">www.smc.eu</a>                     | <a href="mailto:apoiocliente.pt@smc.com">apoiocliente.pt@smc.com</a>   |  |  |  |  |  |  |
| <b>Romania</b>        | +40 213205111       | <a href="http://www.smcromania.ro">www.smcromania.ro</a>       | <a href="mailto:office.ro@smc.com">office.ro@smc.com</a>               |  |  |  |  |  |  |
| <b>Russia</b>         | +7 (812)3036600     | <a href="http://www.smc.eu">www.smc.eu</a>                     | <a href="mailto:sales@smcru.com">sales@smcru.com</a>                   |  |  |  |  |  |  |
| <b>Slovakia</b>       | +421 (0)413213212   | <a href="http://www.smc.sk">www.smc.sk</a>                     | <a href="mailto:sales.sk@smc.com">sales.sk@smc.com</a>                 |  |  |  |  |  |  |
| <b>Slovenia</b>       | +386 (0)73885412    | <a href="http://www.smc.si">www.smc.si</a>                     | <a href="mailto:office.si@smc.com">office.si@smc.com</a>               |  |  |  |  |  |  |
| <b>Spain</b>          | +34 945184100       | <a href="http://www.smc.eu">www.smc.eu</a>                     | <a href="mailto:post.es@smc.com">post.es@smc.com</a>                   |  |  |  |  |  |  |
| <b>Sweden</b>         | +46 (0)86031240     | <a href="http://www.smc.nu">www.smc.nu</a>                     | <a href="mailto:order.se@smc.com">order.se@smc.com</a>                 |  |  |  |  |  |  |
| <b>Switzerland</b>    | +41 (0)523963131    | <a href="http://www.smc.ch">www.smc.ch</a>                     | <a href="mailto:helpcenter.ch@smc.com">helpcenter.ch@smc.com</a>       |  |  |  |  |  |  |
| <b>Turkey</b>         | +90 212 489 0 440   | <a href="http://www.smcturkey.com.tr">www.smcturkey.com.tr</a> | <a href="mailto:satis.tr@smc.com">satis.tr@smc.com</a>                 |  |  |  |  |  |  |
| <b>UK</b>             | +44 (0)845 121 5122 | <a href="http://www.smc.uk">www.smc.uk</a>                     | <a href="mailto:sales.gb@smc.com">sales.gb@smc.com</a>                 |  |  |  |  |  |  |
| <b>South Africa</b>   | +27 10 900 1233     | <a href="http://www.smcza.co.za">www.smcza.co.za</a>           | <a href="mailto:Sales.za@smc.com">Sales.za@smc.com</a>                 |  |  |  |  |  |  |

## www.smc.eu

Release EP  
EACT-01D-UK

SPECIFICATIONS ARE SUBJECT TO CHANGE WITHOUT PRIOR NOTICE AND ANY OBLIGATION ON THE PART OF THE MANUFACTURER