

Compact Cylinder/Double Force Type RoHS

Size: 45, 57, 71

This product is capable of providing double the force of the CQ2 series, without changing the width, due to the adoption of a rectangular piston.

* Comparison with dual stroke cylinders satisfying the following conditions: a cylinder of the same width with double the theoretical output.
 * The width of the CQ2 standard model and the CQ2 dual stroke cylinder are the same.

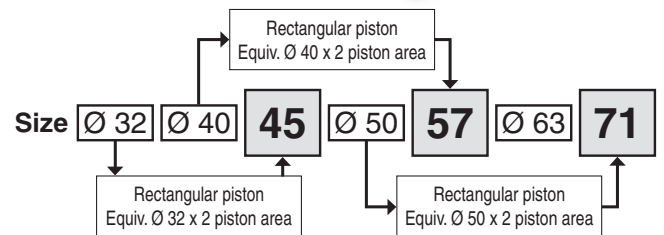
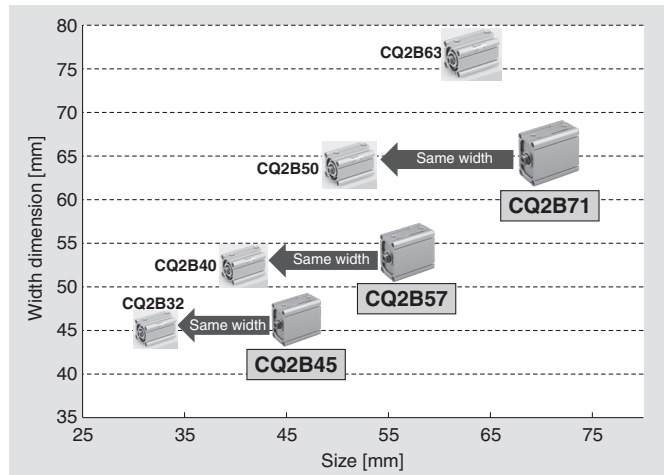

Weight **51%^{*1} reduction**
 648 g → 317 g

Overall length **50%^{*1} reduction**
 130.5 mm → 65 mm

*1 Comparison with the existing model (CDQ2B32-25+0DCZ-XC11 Dual stroke cylinder)

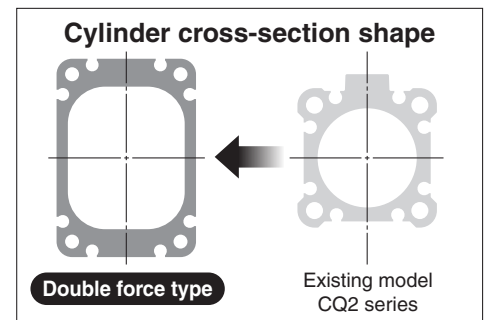

Overall length comparison

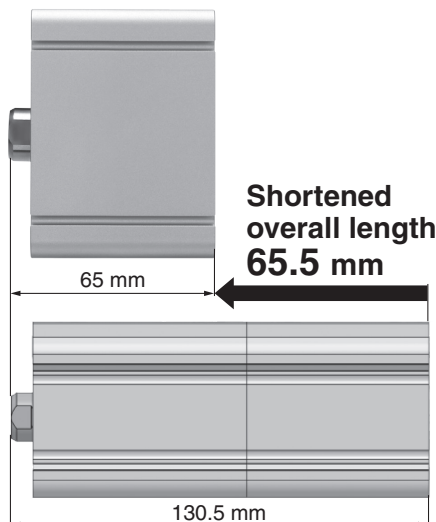

Width comparison

Double force type

Size 45 (Ø 32 x 2),
 25 mm stroke

Same width

Existing model
 Dual stroke cylinder
 (Double force)
 Ø 32, 25 mm stroke

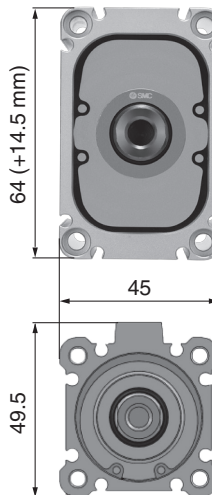

Dual stroke cylinder/ Double force

When air pressure is supplied to the A and C ports at the same time, double the force can be obtained.

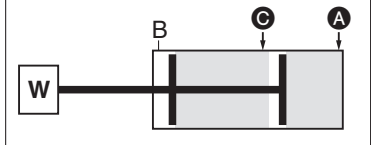

Small auto switches can be mounted on 4 surfaces.

Applicable auto switch: D-M9□

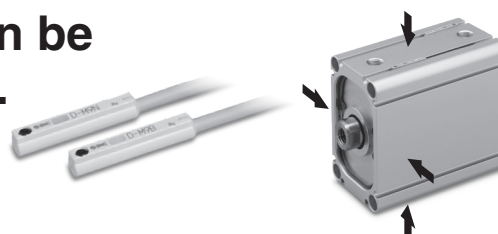

CDQ2B-X3166



19-EU726-UK

CDQ2B-X3166

Specifications

Size	45 (Equiv. $\varnothing 32 \times 2$ piston area)	57 (Equiv. $\varnothing 40 \times 2$ piston area)	71 (Equiv. $\varnothing 50 \times 2$ piston area)
Action	Double acting		
Fluid	Air		
Proof pressure	1.0 MPa		
Max. operating pressure	0.7 MPa*2		
Min. operating pressure	0.05 MPa		
Ambient and fluid temperatures	5 to 60 °C		
Piston speed	50 to 300 mm/s*2		
Cushion	Rubber bumper		
Lubrication	Not required (Non-lube)		
Stroke length tolerance	$^{+1.3}_0$ mm*1		
Allowable kinetic energy	0.26 J	0.46 J	0.77 J

*1 Stroke length tolerance does not include the amount of bumper change.

Depending on the system configuration selected, the specified speed may not be satisfied.

*2 Maximum operating pressure and piston speed are different from the existing product (CQ2 series).

Theoretical Output

Size	Piston area [mm ²]	Rod operating direction	Operating air pressure [MPa]					
			0.2	0.3	0.4	0.5	0.6	0.7
45	1457	IN	291	437	583	729	874	1020
	1611	OUT	322	483	644	806	967	1128
57	2262	IN	452	678	905	1131	1357	1583
	2516	OUT	503	755	1006	1258	1510	1761
71	3548	IN	710	1064	1419	1774	2129	2484
	3928	OUT	786	1178	1571	1964	2357	2750

* Theoretical output [N] = Pressure [MPa] x Piston area [mm²]

Dimensions

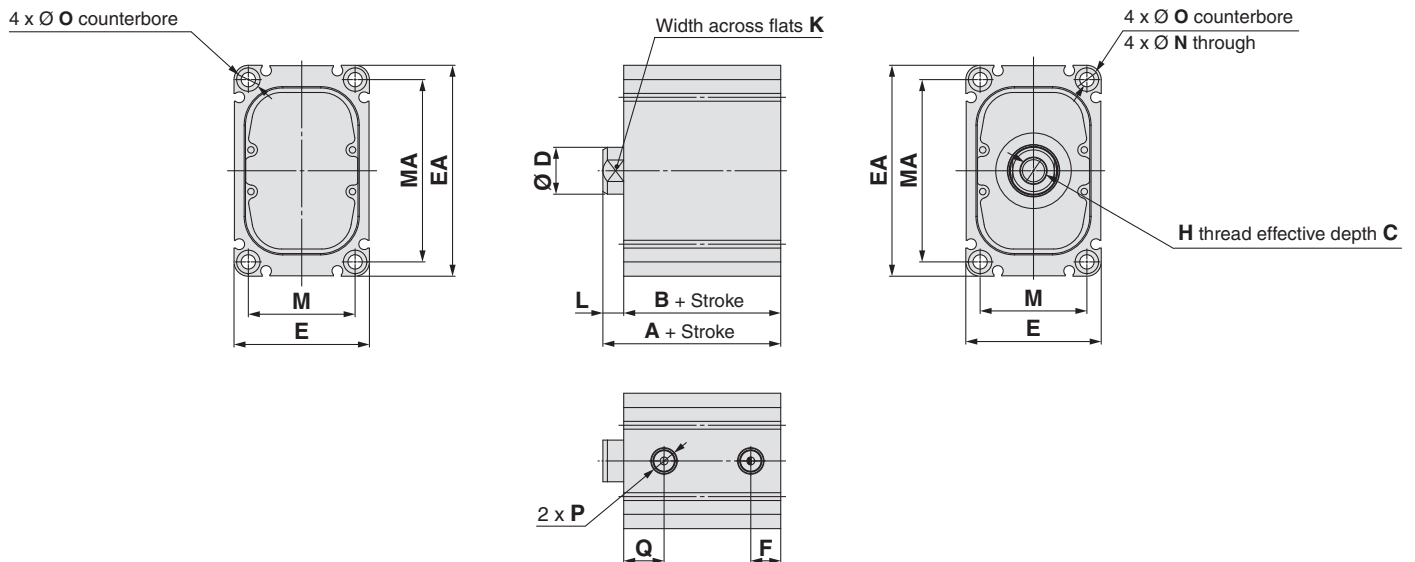

Size	A	B	C	D	E	EA	F	H	K	L	M	MA	N	O	P	Q
45	40.3	34.3	13	14	45	64	10	M8 x 1.25	12	6	35	54	4.5	8 depth 6	Rc1/8	12.5
57	48.3	40.3	15	18	52	81	11.5	M10 x 1.5	16	8	41	70	5.5	9 depth 7	Rc1/8	15.5
71	53.6	44.6	21	22	64	97	14.5	M14 x 2.0	19	9	51	84	6.6	11 depth 8	Rc1/8	17

SMC Corporation (Europe)

SMC Corporation
 Akihabara UDX 15F, 4-14-1, Sotokanda, Chiyoda-ku, Tokyo 101-0021, JAPAN
 Phone: 03-5207-8249 Fax: 03-5298-5362
 SMC CORPORATION All Rights Reserved

European Marketing Centre (EMC)

Zuazobidea 14, 01015 Vitoria
 Tel: +34 945-184 100 Fax: +34 945-184 124
 URL <http://www.smc.eu>